



McElroy Manufacturing, Inc.  
The leader by design.  
Tulsa, Oklahoma U.S.A.

DRAWN: CRN    CHECK: WW    APPRVD: JBC    DATE: 1/19/17    SHT No: 3    REV No: A    PART No: 2511003

LID ASSEMBLY

NOTE: THIS DRAWING AND THE INFORMATION CONTAINED THEREIN IS THE CONFIDENTIAL AND PROPRIETARY PROPERTY OF McElroy Manufacturing, Inc. THE DRAWING IS NOT TO BE REPRODUCED IN ANY MANNER, SUBMITTED TO OUTSIDE PARTIES FOR EXAMINATION, OR USED DIRECTLY OR INDIRECTLY FOR THE PURPOSES OTHER THAN THOSE FOR WHICH IT WAS FURNISHED WITHOUT WRITTEN PERMISSION OF McElroy Manufacturing, Inc.

NOTES:

1. ALL HARDWARE TO BE INSTALLED WITH NYLON LOCK NUTS OR MEDIUM STRENGTH THREAD LOCKER
2. HARDWARE IS: 1/4-20 X 1" LG HEX HEAD CAP SCREW
3. HARDWARE IS: 1/4-20 X 1-3/4" LG HEX HEAD CAP SCREW

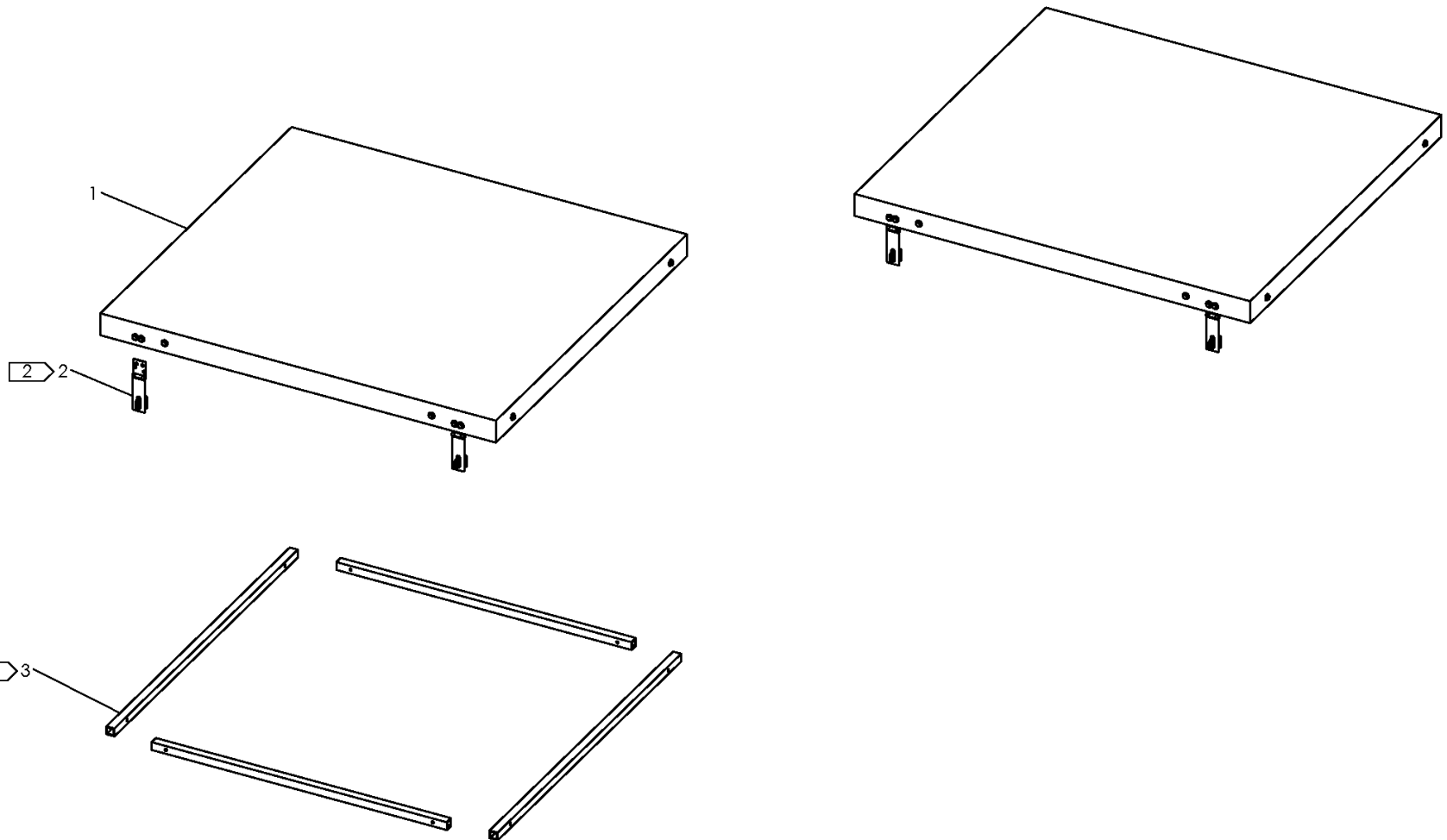

### McElroy Manufacturing Parts List

**Part Number:** 2511003 Lid Assembly

**Part Number 2511003 Component List**

Item	Component	Description	Quantity	Unit	Price
1	2511007	Lid	1.0	EA	0.00
2	2511008	Hasp & Staple Set of 2	1.0	ST	421.00
3	2511009	Rail Spacer Set	1.0	ST	0.00
4	2511010	Rear Lock Bracket Set	1.0	ST	143.00

Please visit <https://fusion.mcelroy.com/parts> to purchase parts or for more information.

