



McElroy Manufacturing, Inc.
The leader by design.
Tulsa, Oklahoma U.S.A.

DRAWN: PJD CHECK: TMT APPRVD: DWP DATE: 10/30/09 SHT No: 1A REV No: D PART No: 6513501

MegaMc® 36-65 PIPE STAND ASSEMBLY

NOTE: THIS DRAWING AND THE INFORMATION CONTAINED THEREIN IS THE CONFIDENTIAL AND PROPRIETARY PROPERTY OF McElroy Manufacturing, Inc. THE DRAWING IS NOT TO BE REPRODUCED IN ANY MANNER, SUBMITTED TO OUTSIDE PARTIES FOR EXAMINATION, OR USED DIRECTLY OR INDIRECTLY FOR THE PURPOSES OTHER THAN THOSE FOR WHICH IT WAS FURNISHED WITHOUT WRITTEN PERMISSION OF McElroy Manufacturing, Inc.

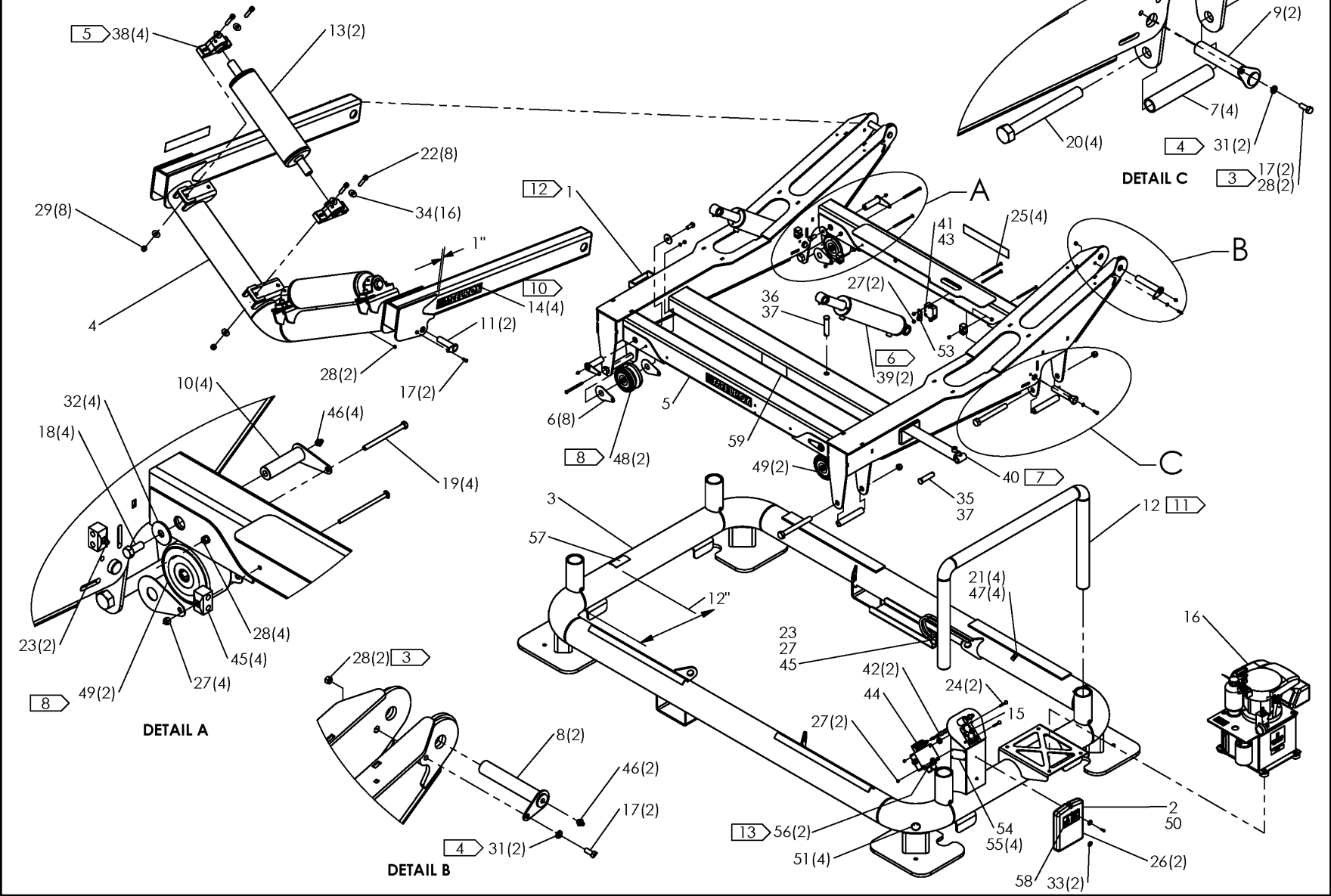



McElroy Manufacturing, Inc.

The leader by design.

Tulsa, Oklahoma U.S.A.

DRAWN: PJD

CHECK: TMT

APPRVD: DWP

DATE: 10/30/09

SHT No: 1B

REV No: D

PART No: 6513501

MegaMc® 36-65 PIPE STAND ASSEMBLY

NOTE: THIS DRAWING AND THE INFORMATION CONTAINED THEREIN IS THE CONFIDENTIAL AND PROPRIETARY PROPERTY OF McElroy Manufacturing, Inc. THE DRAWING IS NOT TO BE REPRODUCED IN ANY MANNER, SUBMITTED TO OUTSIDE PARTIES FOR EXAMINATION, OR USED DIRECTLY OR INDIRECTLY FOR THE PURPOSES OTHER THAN THOSE FOR WHICH IT WAS FURNISHED WITHOUT WRITTEN PERMISSION OF McElroy Manufacturing, Inc.

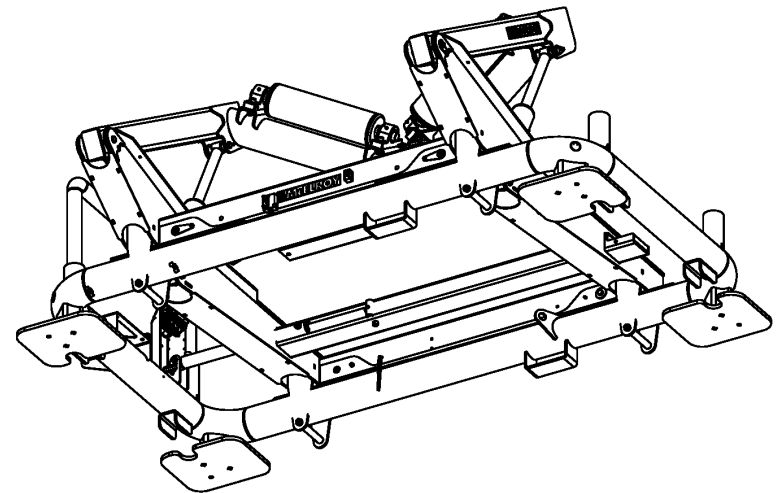
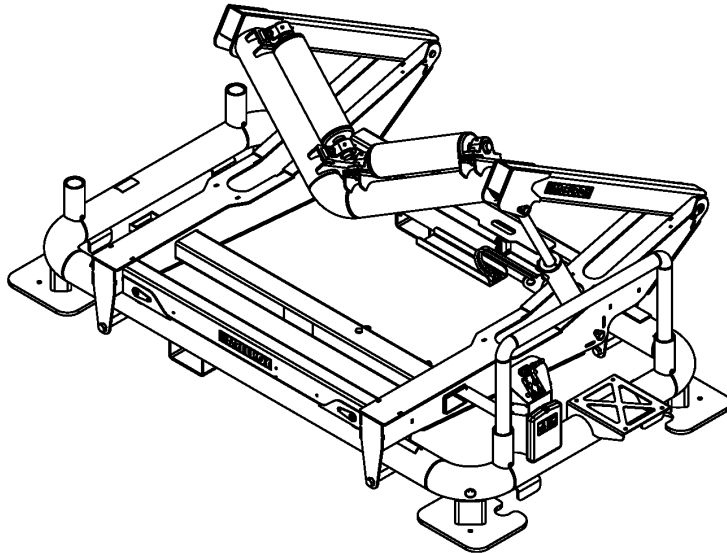
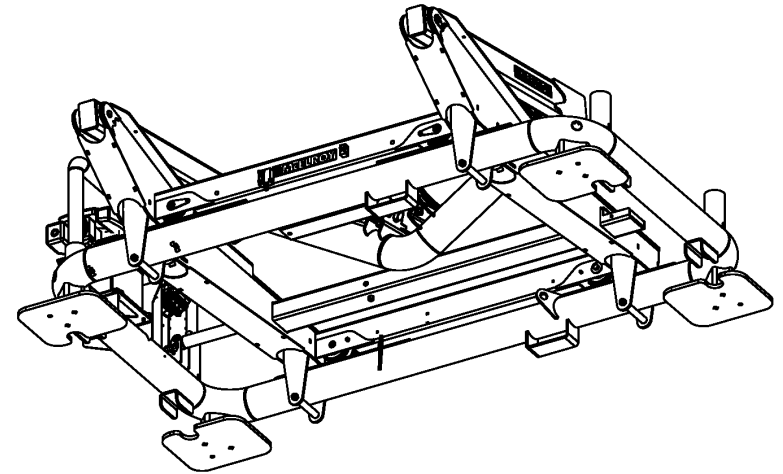
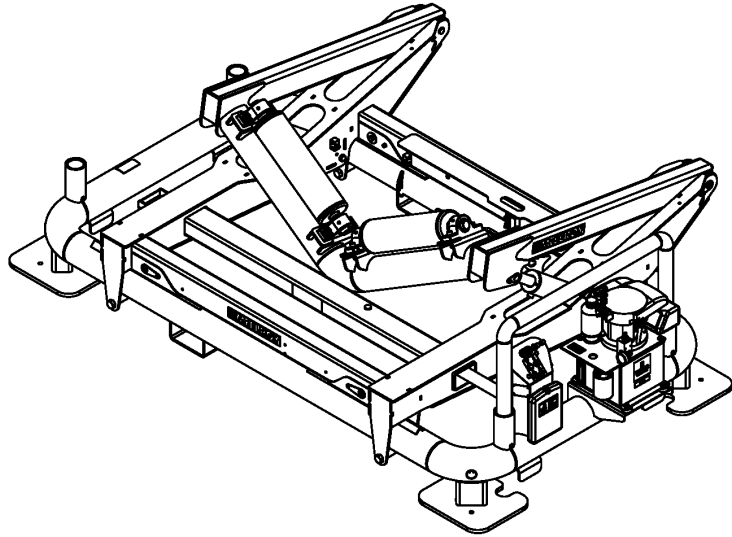



McElroy Manufacturing, Inc.

The leader by design.

Tulsa, Oklahoma U.S.A.

DRAWN: PJD

CHECK: TMT

APPRVD: DWP

DATE: 10/30/09

SHT No: 1C

REV No: D

PART No: 6513501

MegaMc® 36-65 PIPE STAND ASSEMBLY

NOTE: THIS DRAWING AND THE INFORMATION CONTAINED THEREIN IS THE CONFIDENTIAL AND PROPRIETARY PROPERTY OF McElroy Manufacturing, Inc. THE DRAWING IS NOT TO BE REPRODUCED IN ANY MANNER, SUBMITTED TO OUTSIDE PARTIES FOR EXAMINATION, OR USED DIRECTLY OR INDIRECTLY FOR THE PURPOSES OTHER THAN THOSE FOR WHICH IT WAS FURNISHED WITHOUT WRITTEN PERMISSION OF McElroy Manufacturing, Inc.

NOTES:

1. MEDIUM STRENGTH THREAD LOCKER ON ALL SCREWS, BOLTS AND NUTS.
2. SQUARE NECK BOLT HEADS ARE HELD BY SQUARE HOLES IN FRAME.
3. INSERT NUT IN HEX SOCKET OF FRAME (LOCATED INBOARD).
4. PLACE LOCK WASHER UNDER HEAD OF BOLT. USED AS A SPACER WASHER TO ASSURE CLEARANCE TO BOLT TIP.
5. APPLY A THIN OIL FILM TO SHAFT AND BEARING BORE THEN SLIDE PILLOW BLOCK ON THE SHAFT WITH THE LOCKING COLLAR FACING THE ROLLER. LEAVE 1/32" GAP BETWEEN OUTBOARD BEARING COLLAR AND SHAFT SHOULDER. PATTERN AND STEP TORQUE MOUNTING BOLTS TO 150 FT-LBS. KEEP BEARINGS SQUARE WITH SHAFT AND MAINTAIN 1/32" GAP SO THEY ARE NOT PUT IN A BIND. AFTER TIGHTENING MOUNTING BOLTS, LOCK BEARING ECCENTRIC COLLAR FIRMLY IN PLACE BY TURNING CLOCKWISE (FACING BEARING) BY HAND UNTIL TIGHT THEN LOCK IT FIRMLY IN PLACE WITH A SPANNER WRENCH OR HAMMER AND DRIFT (ONE OR TWO GOOD BLOWS IS SUFFICIENT). TIGHTEN TWO SET SCREWS TO 25 FT-LBS.
6. THE LIFT CYLINDER PORTS AND BOTH CROSS TUBE ZERK FITTINGS SHOULD FACE DOWN/FORWARD. THE HYDRAULIC 90 DEG FITTING ON THE LIFT CYLINDER BARREL SHOULD POINT DOWN, REARWARD AND ANGLED INBOARD 45 DEGREES SO THAT THE HOSES SPIRAL INBOARD AND DO NOT CHAFE ON THE FRAME.
7. TRANSVERSE CYLINDER ROD ZERK FITTING SHOULD POINT REARWARD, TOWARDS THE ACCESS HOLE. TRANSVERSE CYLINDER BARREL ZERK FITTING SHOULD POINT UPWARD.
8. PULL OUT GREASE ZERK FROM ALL WHEELS AND DISCARD.
9. USING A GREASE GUN APPLY GREASE TO THE FOLLOWING PLACES:
WHEELS VIA GREASE ZERK ON PINS, 4 PLACES
CYLINDER PINS VIA GREASE ZERK ON CROSS TUBES, 6 PLACES
BOOM PINS VIA GREASE ZERK ON PINS, 2 PLACES
THE PILLOW BLOCK BEARINGS ARE FACTORY LUBRICATED AND DO NOT NEED ADDITIONAL GREASE.
10. CENTER MCELROY LABELS VERTICALLY AND HORIZONTALLY ON TROLLEY CROSS TUBES OUTBOARD FACES (FRONT AND REAR). CENTER MCELROY LABELS VERTICALLY ON BOOM ARMS OUTBOARD FACES (LEFT AND RIGHT) AND 1" REARWARD OF LAP PLATE.
11. CHECK THAT GUARD RAIL SLIPS EASILY INTO AND OUT OF BOTH FAR SIDE AND NEAR SIDE SOCKETS. IT SHOULD BE PLACED ON THE NEAR SIDE SOCKETS, OVER THE ENGINE AND CONTROLS.
12. STOW LIFTING SLING INSIDE CENTER CROSS TUBE.
13. PLACE WASHERS BETWEEN VALVE AND PODIUM, ON SQUARE NECK OF BOLTS.

McElroy Manufacturing Parts List

Part Number: 6513501 MegaMc 36-65 Pipe Stand Assembly

Part Number 6513501 Component List

Item	Component	Description	Quantity	Unit	Price
1	6513301	MegaMc 36"-65" Pipe Stand Lifting Sling	1.0	EA	640.00
2	6513401	MegaMc Pipe Stand Operator's Manual	1.0	EA	142.00
3	6513901	Base Frame Wld (Effective to 11/19/09)	1.0	EA	0.00
3	6513914	Base Frame	1.0	EA	0.00
4	6514201	Boom Wld	1.0	EA	0.00
5	6514501	Trolley Wld	1.0	EA	0.00
6	6514601	Wheel Thrust Washer	8.0	EA	0.00
7	6514701	Hold Down Spacer	4.0	EA	0.00
8	6515101	Boom Pin Wld	2.0	EA	0.00
9	6515201	Cylinder Pin Wld	2.0	EA	65.18
10	6515301	Wheel Pin Wld	4.0	EA	0.00
11	6515401	Cylinder Rod Pin Wld	2.0	EA	0.00
12	6515901	Guard Rail Wld	1.0	EA	1,429.00
13	6516201	Roller Wld	2.0	EA	0.00
14	8163120	Large McElroy Branding Label	4.0	EA	6.41
15	8163173	Hyd Pipe Stand Pos Cntrl Label	1.0	EA	0.00
16	LT0172	LineTamer 5.5 HP Gas Hydraulic Power Unit Assembly	1.0	EA	4,729.00
17	MAB00064	3/8-16NCX1LG Hhcs	6.0	EA	0.51
18	MAB00075	5/8-11NCX1-1/2LG Hhcs	4.0	EA	1.19
19	MAB00097	3/8-16NCX5LG Hhcs	4.0	EA	1.39
20	MAB00187	1-8NCX9LG Hhcs	4.0	EA	0.00
21	MAC00036	#10-24NCX1/2LG Shcs PL	4.0	EA	0.39
22	MAC00168	5/8-11NCX2-3/4LG Shcs PL	8.0	EA	0.00
23	MAI00007	5/16-18NC X 2-1/4 LG Crg Bolt	3.0	EA	0.51
24	MAI00008	5/16-18NC X 2-3/4 LG Crg Bolt	2.0	EA	0.00
25	MAI00009	5/16-18NC X 6 LG Crg Bolt	4.0	EA	0.00
26	MAL00007	1/4-20NCX3/4LG Hwh TF Screw	2.0	EA	0.49
27	MBA00006	5/16-18NC Fnsh Hex Nut Stl PL	9.0	EA	0.33
28	MBA00007	3/8-16NC Fnsh Hex Nut Stl PL	10.0	EA	0.29
29	MBA00011	5/8-11NC Fnsh Hex Nut Stl PL	8.0	EA	0.70
30	MBA00014	1-8NC Fnsh Hex Nut Stl PL	4.0	EA	0.00
31	MBE00007	3/8 Reg Split Lck Wshr Stl PL	4.0	EA	0.12
32	MBF00011	5/8 TY 'a' Wide FL Wshr Stl PL	4.0	EA	0.40
33	MBF00005	1/4 TY 'a' Wide FL Wshr Stl PL	2.0	EA	0.11
33	MBG00031	1/4 Fender Washer Stl PL (Effective to 2/9/10)	2.0	EA	0.31
34	MBG00086	5/8 Hardened Flat Washer	16.0	EA	4.28
35	MCF00048	1DIA X3-45/64 Grip Clv Pin PL	1.0	EA	0.00
36	MCF00049	1DIA X4-13/64 Grip Clv Pin PL	1.0	EA	0.00
37	MCH00027	3/16DIA X2LG Cotter Pin	2.0	EA	0.40
38	MDM00407	Pillow Block Bearing	4.0	EA	0.00
39	MEB00159	4B X 18S X 2R Hyd Cylinder	2.0	EA	1,865.00
40	MEB00160	2B X 24S X 1R Hyd Cylinder	1.0	EA	753.00
41	MEF00061	Counter Balance Valve	1.0	EA	249.00
42	MEF00077	Valve Hand Lever	2.0	EA	7.04
43	MEF00124	Valve Body	1.0	EA	118.00
44	MEF00204	2-SPOOL Dir Valve, Less Hdl	1.0	EA	782.00
45	MFD00081	Hose Clamp	5.0	EA	14.92
46	MFJ00002	1/8NPT Grease Zerk	6.0	EA	1.18
47	MHA00033	1/2 Hose Clamp	4.0	EA	6.39
48	MID00015	6" V-groove Steel Wheel Caster	2.0	EA	0.00
49	MID00016	6" Dia Steel Wheel Caster	2.0	EA	0.00
50	MJQ00259	Standard 9x6 Literature Compartment	1.0	EA	62.90
51	MJQ00379	Ylw, Blk Hook Lift Point Label	4.0	EA	6.90
52	6513601	MegaMc 36"-65" Hydraulic Pipe Stand Plumbing Schematic	1.0	EA	0.00

McElroy Manufacturing Parts List

Part Number: 6513501 MegaMc 36-65 Pipe Stand Assembly

53	3646301	Bulkhead Bracket	1.0 EA	0.00
54	PL2-6513501	Nameplate	1.0 EA	0.00
55	MCK00005	1/8DIAX .462" Grip Blind Rivet	4.0 EA	0.39
56	MBF00009	1/2 TY 'a' Wide FL Wshr Stl PL	2.0 EA	0.25
57	2453401	Crush Hazard Safety Label	1.0 EA	0.00
58	816342	Safety Instr Manual Label	1.0 EA	3.16
59	8163177	Hyd Pipe Stand Safe Lift Label	1.0 EA	0.00

Please visit <https://fusion.mcelroy.com/parts> to purchase parts or for more information.

