



McElroy Manufacturing, Inc.
The leader by design.
Tulsa, Oklahoma U.S.A.

DRAWN: DCG CHECK: PJD APPRVD: MRP DATE: 3/21/16 SHT No: 1 REV No: B PART No: SW24801

HORNET DRILL ADAPTER ASSEMBLY

NOTE: THIS DRAWING AND THE INFORMATION CONTAINED THEREIN IS THE CONFIDENTIAL AND PROPRIETARY PROPERTY OF McElroy Manufacturing, Inc. THE DRAWING IS NOT TO BE REPRODUCED IN ANY MANNER, SUBMITTED TO OUTSIDE PARTIES FOR EXAMINATION, OR USED DIRECTLY OR INDIRECTLY FOR THE PURPOSES OTHER THAN THOSE FOR WHICH IT WAS FURNISHED WITHOUT WRITTEN PERMISSION OF McElroy Manufacturing, Inc.

NOTES:

- 1. INSTALL MEDIUM STRENGTH THREAD LOCKER BETWEEN ITEMS 2 AND 5.
- 2. INSTALL ITEM 4 WITH RETAINING COMPOUND, IF NEEDED.

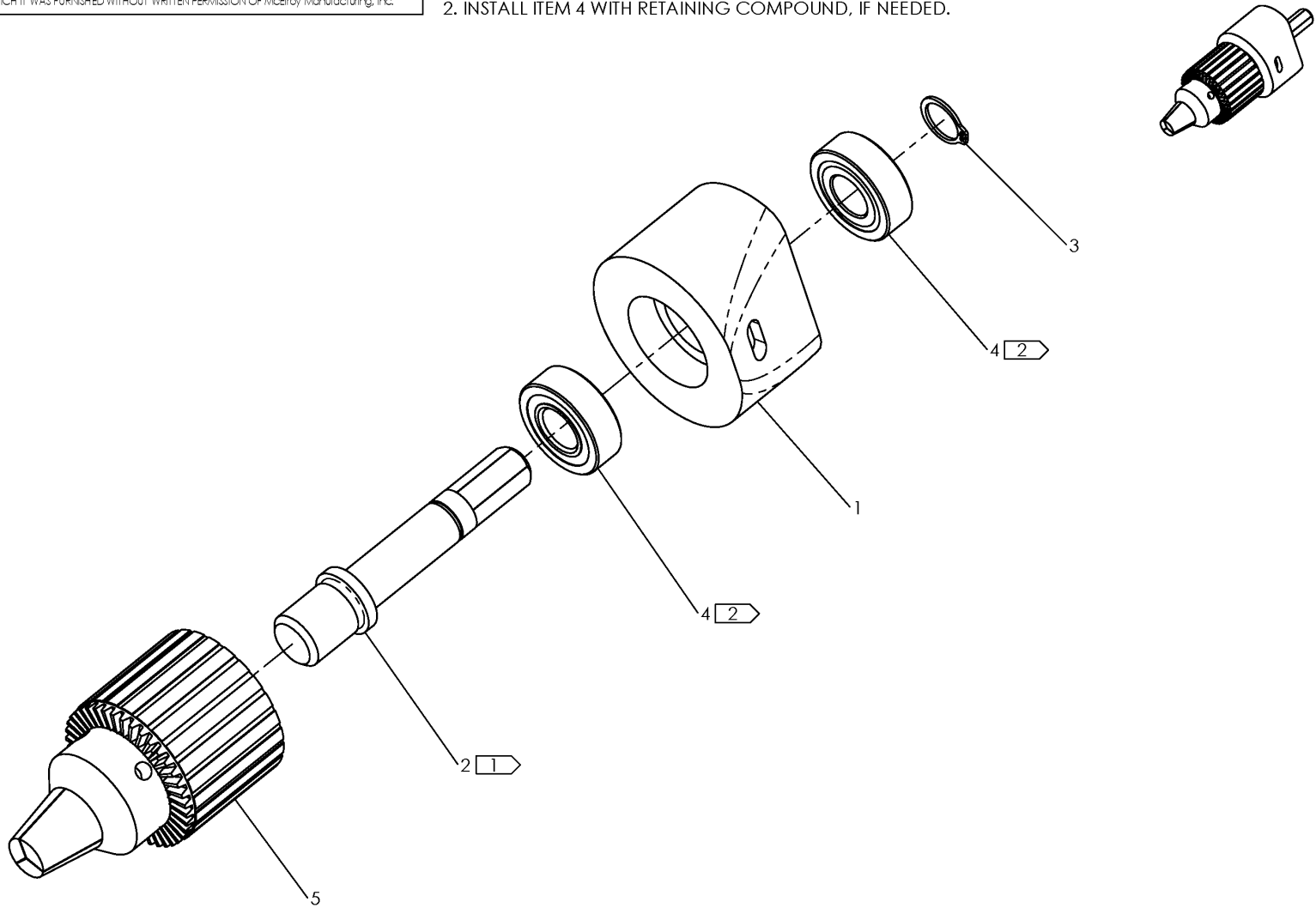

McElroy Manufacturing Parts List

Part Number: SW24801 Hornet Drill Adapter Assembly

Part Number SW24801 Component List

Item	Component	Description	Quantity	Unit	Price
1	SW25101	Drill Adapter Housing	1.0	EA	0.00
2	SW25201	Drill Adapter Shaft	1.0	EA	159.00
3	MCB00086	1/2"OD Retaining Ring PL	1.0	EA	0.67
4	MDM00026	Ball Bearing	2.0	EA	10.20
5	MNG00020	1/2" Drill Chuck	1.0	EA	155.00

Please visit <https://fusion.mcelroy.com/parts> to purchase parts or for more information.

