



McElroy Manufacturing, Inc.
The leader by design.
Tulsa, Oklahoma U.S.A.

DRAWN: BWW CHECK: BLM APPRVD: SWB DATE: 07/29/03 SHT No: 1 REV No: U PART No: 1869501

#412/#618 GAS/ELECTRIC ROLLING CHASSIS ASSEMBLY

NOTE: THIS DRAWING AND THE INFORMATION CONTAINED THEREIN IS THE CONFIDENTIAL AND PROPRIETARY PROPERTY OF McElroy Manufacturing, Inc. THE DRAWING IS NOT TO BE REPRODUCED IN ANY MANNER, SUBMITTED TO OUTSIDE PARTIES FOR EXAMINATION, OR USED DIRECTLY OR INDIRECTLY FOR THE PURPOSES OTHER THAN THOSE FOR WHICH IT WAS FURNISHED WITHOUT WRITTEN PERMISSION OF McElroy Manufacturing, Inc.

NOTES:

1. PACK WHEEL HUB AND BEARINGS AND FILL PIPE LIFT ROLLER WITH EP GREASE.
2. ATTACH NAMEPLATE AT FINAL ASSEMBLY USING (4) DRIVE SCREWS.
3. ITEM-16 MIB00001 INCLUDES : (1)MBD00041 AXLE NUT, (1) MCH00005 COTTER PIN (1) MDL00120 SEAL, (2) MDM00189 TAPERED ROLLER BEARING CONES, (1) MIB00011 GREASE CAP, AND (4) LUG BOLTS. THE PART NO.'S SHOWN MAY BE ORDERED SEPARATELY.
4. INSTALL WITH MEDIUM STRENGTH THREAD LOCKER.
5. WHEN ORDERING REPLACEMENT PARTS FOR BRAKE WHEEL ASSEMBLY, DISCARD LUG BOLTS SUPPLIED WITH WHEEL AND TIRE ASSEMBLY AND ORDER (4) 'ITEM 1' MAB00165 AND (4) 'ITEM 4' MBH00061 TO ENSURE PROPER THREAD ENGAGEMENT.
6. ITEMS SHOWN IN PARENTHESIS REFLECT QUANTITIES IN A LOCAL GROUP AND MAY NOT INDICATE TOTAL ASSEMBLY QUANTITIES.
7. REMOVE PLASTIC BEAD CHAIN AND REPLACE WITH STEEL BEAD CHAIN ITEM 31.
8. MACHINES BUILT THROUGH Q12019 WITH PIVOT CENTERED IN AXEL WELDMENT USED 1871135 CHASSIS AND 1869601 AXLE ASSEMBLY.

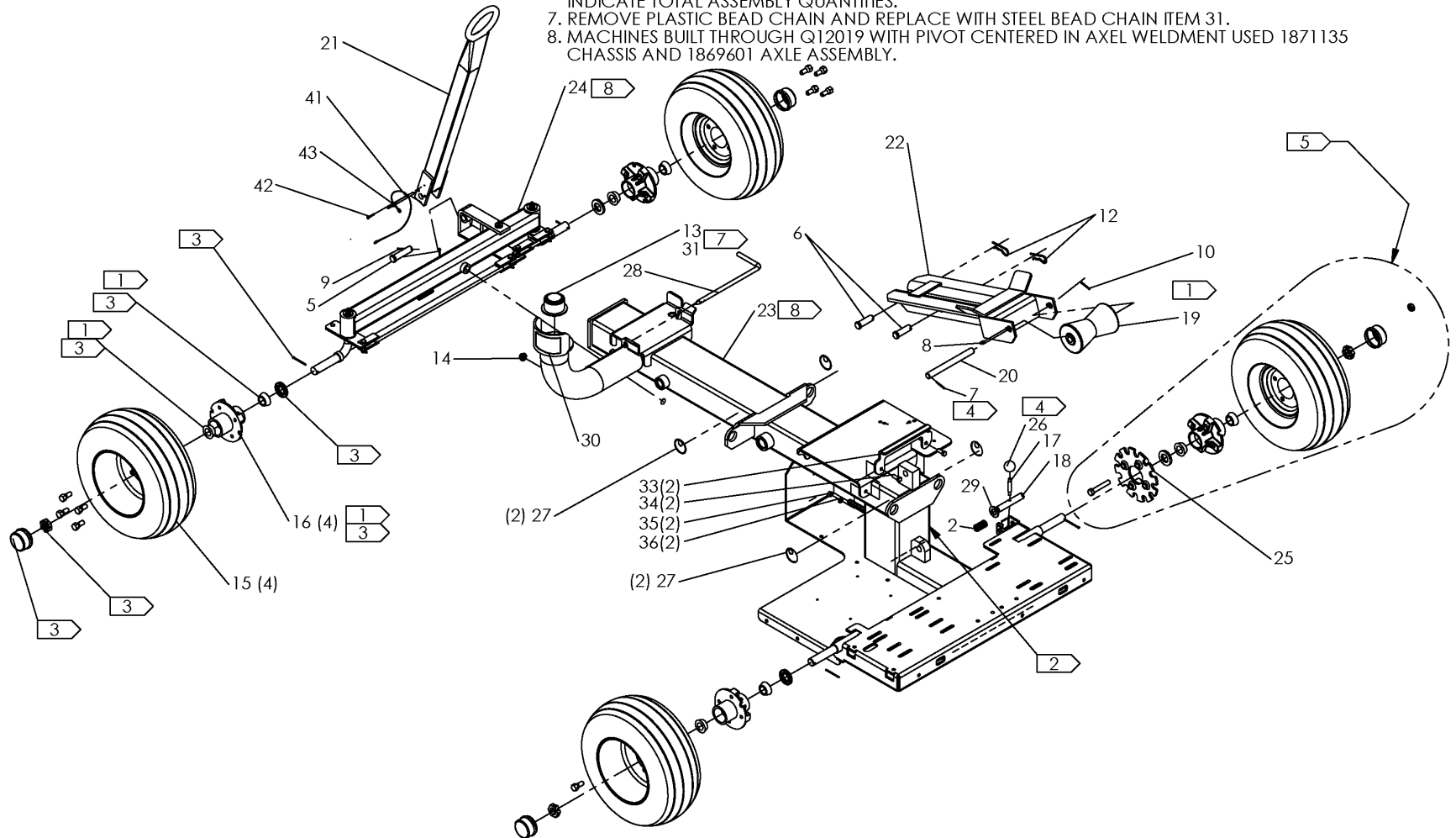

McElroy Manufacturing Parts List

Part Number: 1869501 412/618 Gas/Electric Rolling Chassis Assembly

Part Number 1869501 Component List

Item	Component	Description	Quantity	Unit	Price
1	MAB00165	1/2-20NFX3LG Hhcs-full Thread	4.0	EA	7.37
2	MJE00028	Compression Spring	1.0	EA	5.54
4	MBH00061	1/2-20NF Lug Nut	4.0	EA	3.90
5	MCF00004	3/4DIAX2-27/32 Grip Clv Pin PL	1.0	EA	8.40
6	MCF00016	3/4DIAX2-11/32GRIP Clv Pin PL	2.0	EA	4.45
7	MCG00024	1/8DIAX1-1/2LG Roll Pin	1.0	EA	0.27
8	MCG00028	1/4DIAX1/2LG Roll Pin	1.0	EA	0.13
9	MCH00001	1/8DIAX1LG Cotter Pin	1.0	EA	0.11
10	MCH00004	1/8DIAX1-1/4LG Cotter Pin	1.0	EA	0.11
12	MCH00021	3/4DIAX2-11/16LG Hair Pin	2.0	EA	1.57
13	MFK00004	Black Filler Cap	1.0	EA	67.27
14	MFJ00013	Oil Eye Lense & O-ring	1.0	EA	14.33
15	MIA00005	Wheel & 16.5 X 6.50 Tire Assy	4.0	EA	134.00
16	MIB00001	Hub W/ BRG,SEAL,CAPS&(4) Nuts	4.0	EA	82.73
17	MJJ00028	Handle Shaft	1.0	EA	28.92
18	1871601	Brake Plunger (Effective 11/1/04 to 5/9/18)	1.0	EA	53.92
18	1871602	Brake Plunger	1.0	EA	36.49
19	802105	Pipe Lift Roller W/zerk	1.0	EA	154.00
20	812802	12/18 Pipe Lift Roller Shaft	1.0	EA	26.76
21	1209402	Tow Bar Weldment	1.0	EA	222.00
22	1855401	Pipe Lift Arm Weldment	1.0	EA	329.00
23	1871101	Chassis Wld (Effective 3/27/03 to 3/4/14)	1.0	EA	3,877.00
23	1871135	Chassis Wld (Effective 3/5/14 to 11/25/18)	1.0	EA	3,877.00
23	1871136	Chassis Wld	1.0	EA	0.00
24	1869601	412/618 Front Axle Assembly (Effective 3/24/03 to 11/25/18)	1.0	EA	923.00
24	1869602	412/618 Front Axle Assembly (Offset Pivot)	1.0	EA	0.00
25	1871701	Brake Plate Wld	1.0	EA	117.00
26	MJJ00029	Red OR Black Ball Knob	1.0	EA	7.93
27	MJQ00379	Ylw, Blk Hook Lift Point Label	4.0	EA	4.05
28	T1203201	Carriage Lock Bar	1.0	EA	12.35
29	MBG00004	3/4 Type 'an' FL Wshr Stl PL	1.0	EA	2.39
30	8163106	Hyd Oil Specification Label	1.0	EA	9.74
31	MJQ00411	3/16" Steel Bead Chain	4.0	IN	0.55
32	MCH00015	3/8DIAX1-7/8LG Hair Pin (Effective 3/17/08 to 6/25/14)	1.0	EA	0.75
33	1871201	12/18 Ring Chassis Hook Plate	1.0	EA	32.48
34	MAB00064	3/8-16NCX1LG Hhcs	2.0	EA	0.36
35	MBA00007	3/8-16NC Fnsh Hex Nut Stl PL	2.0	EA	0.28
36	MBE00007	3/8 Reg Splt Lck Wshr Stl PL	2.0	EA	0.11
37	T5064601	Pipe Lift Valve Guard	1.0	EA	95.07
38	MAB00042	5/16-18NCX3-1/4LG Hhcs	2.0	EA	0.65
39	MBE00006	5/16 Reg Splt Lck Wshr Stl PL	2.0	EA	0.10
40	MBA00006	5/16-18NC Fnsh Hex Nut Stl PL	2.0	EA	0.28
41	MCE00003	1/4 DIAX3.00 Grip Detent Pin	1.0	EA	11.60
42	MAH00140	#6-32NCX1/4LG Hwh TC Screw	1.0	EA	0.28
43	MCK00099	3/64X6" 2-TERMINAL Lanyard	1.0	EA	7.70

Please visit <https://fusion.mcelroy.com/parts> to purchase parts or for more information.