

Operator's Manual



McELROY

www.mcelroy.com



Guided Side Bend Tester

Manual: S07101 Revision: E 4/25

Original Language: English



 WARNING	Cancer and Reproductive Harm - www.P65warnings.ca.gov
--	--

8165961

This product and other products could be protected by patents or have patents pending. All the latest patent information is available at patent.mcelroy.com



Introduction



Thank You for purchasing this McElroy product

The Guided Side Bend Tester provides a quick and easy way to qualitatively test joints in the field.

The Guided Side Bend Tester is a hydraulic hand pump machine that is used to test fusion joint coupons. It can be used to test joints made from pipe up to 7 inches wall thickness. It tests the coupon to see if it will fail under a three point bend test. The coupon is loaded into the machine and the hand pump is used to pressure a hydraulic cylinder that bends the coupon demonstrating ductility in the joint.

With reasonable care and maintenance, this equipment will give years of satisfactory service.

Before operating this machine, please read this manual thoroughly, and keep a copy with the machine for future reference. This manual is to be considered part of your machine.



TX04376-11-7-11

McElroy University

For more than 30 years, McElroy has been the only pipe fusion machine manufacturer to continuously offer advanced training. Course offerings are meant to enhance your efficiency, productivity and safety in the proper use of McElroy machines. McElroy University classes are structured so that the skills learned and the machines used in each class closely match the machines found on pipelining jobsites. We offer training at our facility or yours. Our uniquely qualified McElroy University course instructors offer years of industry experience.

Tuition for each course includes lunches, course materials and a certificate of completion. Online registration, as well as up-to-date course offerings and dates, is available at www.mcelroy.com/university

This manual is intended as a guide only and does not take the place of proper training by qualified instructors. The information in this manual is not all inclusive and can not encompass all possible situations that can be encountered during various operations.



MU2-03-13-14

TX04659-03-24-14



Warranty



LIMITED WARRANTY

McElroy Manufacturing, Inc. (McElroy) warrants all products manufactured, sold and repaired by it to be free from defects in materials and workmanship, its obligation under this warranty being limited to repairing or replacing at its factory and new products, within **5 years** after shipment, with the exception of purchased items (such as electronic devices, pumps, switches, etc.), in which case that manufacturer's warranty applies. Warranty applies when returned freight is prepaid and which, upon examination, shall disclose to have been defective. This warranty does not apply to any product or component which has been repaired or altered by anyone other than McElroy or has become damaged due to misuse, negligence or casualty, or has not been operated or maintained according to McElroy's printed instructions and warnings. This warranty is expressly in lieu of all other warranties expressed or implied. The remedies of the Buyer are the exclusive and sole remedies available and Buyer shall not be entitled to receive any incidental or consequential damages. Buyer waives the benefit of any rule that disclaimer of warranty shall be construed against McElroy and agrees that such disclaimers herein shall be construed liberally in favor of McElroy.

RETURN OF GOODS

Buyer agrees not to return goods for any reason except upon the written consent of McElroy obtained in advance of such return, which consent, if given, shall specify the terms and conditions and charges upon which any such return may be made. Materials returned to McElroy, for warranty work, repair, etc., **must have a Return Material Authorization (RMA) number**, and be so noted on the package at time of shipment. For assistance, inquiry shall be directed to:

McElroy Manufacturing, Inc.
 P.O. Box 580550
 833 North Fulton Street Tulsa, Oklahoma 74158-0550
 PHONE: (918) 836-8611, FAX: (918) 831-9285.
 EMAIL: fusion@McElroy.com

Note: Certain repairs, warranty work, and inquiries may be directed, at McElroy's discretion, to an authorized service center or distributor.

TX02486-11-4-13

DISCLAIMER OF LIABILITY

McElroy accepts no responsibility of liability for fusion joints. Operation and maintenance of the product is the responsibility of others. We recommend qualified joining procedures be followed when using McElroy fusion equipment.

McElroy makes no other warranty of any kind whatever, express or implied; and all implied warranties of merchantability and fitness for a particular purpose which exceed the aforesaid obligation are hereby disclaimed by McElroy.

PRODUCT IMPROVEMENT

McElroy reserves the right to make any changes in or improvements on its products without incurring any liability or obligation to update or change previously sold machines and/or the accessories thereto.

INFORMATION DISCLOSED

No information of knowledge heretofore or hereafter disclosed to McElroy in the performance of or in connection with the terms hereof, shall be deemed to be confidential or proprietary, unless otherwise expressly agreed to in writing by McElroy and any such information or knowledge shall be free from restrictions, other than a claim for patent infringement, is part of the consideration hereof.

PROPRIETARY RIGHTS

All proprietary rights pertaining to the equipment or the components of the equipment to be delivered by McElroy hereunder, and all patent rights therein, arising prior to, or in the course of, or as a result of the design or fabrication of the said product, are exclusively the property of McElroy.

LAW APPLICABLE

All sales shall be governed by the Uniform Commercial Code of Oklahoma, U.S.A.

Register your product online to activate your warranty: www.McElroy.com/fusion

(Copy information listed on the machine nameplate here for your records).

Model No.

Serial No.

Date Received

Distributor



Table of Contents



Equipment Safety

Safety Alerts	1-1
Read and Understand	1-1
General Safety	1-2
Wear Safety Equipment	1-2
Power Tool Safety	1-2

Overview

Guided Side Bend Tester	2-1
Tester	2-1
Pump	2-2
Pressure Release Valve	2-2
Coupon	2-2
Additional Tools	2-3

Operation

Read Before Operating	3-1
Cutting Rough Cut Segment	3-1
Plane the Rough Cut Segment	3-2
Test the Coupon	3-3
Inspect Coupon/Interpret Result	3-4

Maintenance

Preventative Maintenance	4-1
Cleaning the Machine	4-1
Check Hydraulic Fluid	4-1
Bleeding the Hydraulic System	4-2
Fasteners Must Be Tight	4-2

Maintenance Checklist

Maintenance Checklist	5-1
-----------------------------	-----

Specifications

Guided Side Bend Tester	6-1
-------------------------------	-----

COPYRIGHT © 2025, 2018, 2015, 2014, 2012

McELROY MANUFACTURING, INC.

Tulsa, Oklahoma, USA

All rights reserved



Fusion Equipment Safety



Safety Alerts



This hazard alert sign appears in this manual. When you see this sign, carefully read what it says. **YOUR SAFETY IS AT STAKE.**

You will see the hazard alert sign with these words: **DANGER**, **WARNING**, and **CAUTION**.



WR00051-11-30-92



Indicates an imminently hazardous situation which, if not avoided, will result in death or serious injury.



Indicates a potentially hazardous situation which, if not avoided, could result in death or serious injury.



Indicates a hazardous situation which, if not avoided, may result in minor or moderate injury.



In this manual you should look for two other words: **NOTICE** and **IMPORTANT**.

NOTICE: can keep you from doing something that might damage the machine or someone's property. It may also be used to alert against unsafe practices.

IMPORTANT: can help you do a better job or make your job easier in some way.

TX00030-12-1-92

Read and Understand

Do not operate this equipment until you have carefully read, and understand all the sections of this manual, and all other equipment manuals that will be used with it.

Your safety and the safety of others depends upon care and judgment in the operation of this equipment.

Follow all applicable federal, state, local, and industry specific regulations.

McElroy Manufacturing, Inc. cannot anticipate every possible circumstance that might involve a potential hazard. The warnings in this manual and on the machine are therefore not all inclusive. You must satisfy yourself that a procedure, tool, work method, or operating technique is safe for you and others. You should also ensure that the machine will not be damaged or made unsafe by the method of operation or maintenance you choose.

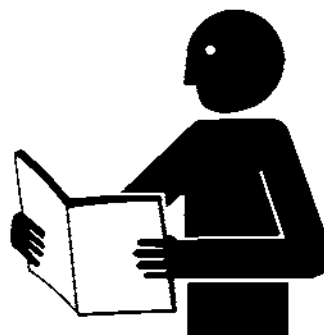

WR00052-12-1-92

TX02946-4-15-09



Fusion Equipment Safety



General Safety

Safety is important. Report anything unusual that you notice during set up or operation.

LISTEN for thumps, bumps, rattles, squeals, air leaks, or unusual sounds.

SMELL odors like burning insulation, hot metal, burning rubber, hot oil, or natural gas.

FEEL any changes in the way the equipment operates.

SEE problems with wiring and cables, hydraulic connections, or other equipment.

REPORT anything you see, feel, smell, or hear that is different from what you expect, or that you think may be unsafe.



SAFE1ST-12-22-92

TX00114-4-22-93

Wear Safety Equipment

Wear a hard hat, safety shoes, safety glasses, and other applicable personal protective equipment.

Remove jewelry and rings, and do not wear loose-fitting clothing or long hair that could catch on controls or moving machinery.

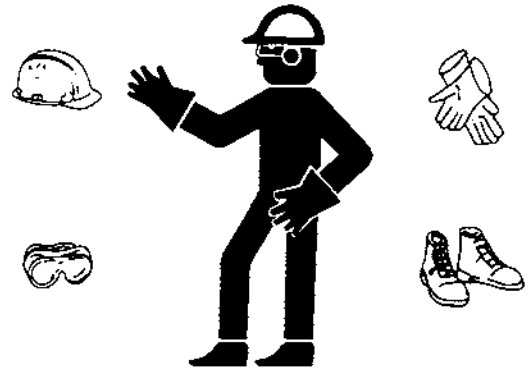

WR00053-12-2-92

TX00032-4-7-93

Power Tool Safety



Read and understand the all instructions provided with your accessory equipment. Failure to follow all the equipment instructions, may result in electric shock, fire and/or serious personal injury.



AEM001r-11-1-11

WR00055-4-7-93

TX04087-11-1-11



Overview



Guided Side Bend Tester

The Guided Side Bend Tester is a hydraulic hand pump machine that is used to test fusion joint coupons. It can be used to test joints made from pipe up to 7 inches wall thickness. It tests the coupon to see if it will fail under a three point bend test. The coupon is loaded into the machine and the hand pump is used to pressure a hydraulic cylinder that bends the coupon demonstrating ductility in the joint.



TX04361-11-1-11

Tester

The Guided Side Bend Tester is equipped with a 1 inch diameter ram and two supporting pins. A hydraulic cylinder moves the ram up and down along a guide in the fixture. The hydraulic cylinder is mounted on the top of the fixture and connects to a hydraulic hand pump.

Support pins are mounted in bearings that allow the support pins to rotate, reducing friction on the coupon during the test.

There are two different bend angle labels. The yellow bend angle label indicates the exterior bend angle and the white bend angle label indicates the interior bend angle (included angle). Use the appropriate label that matches the standard being used.

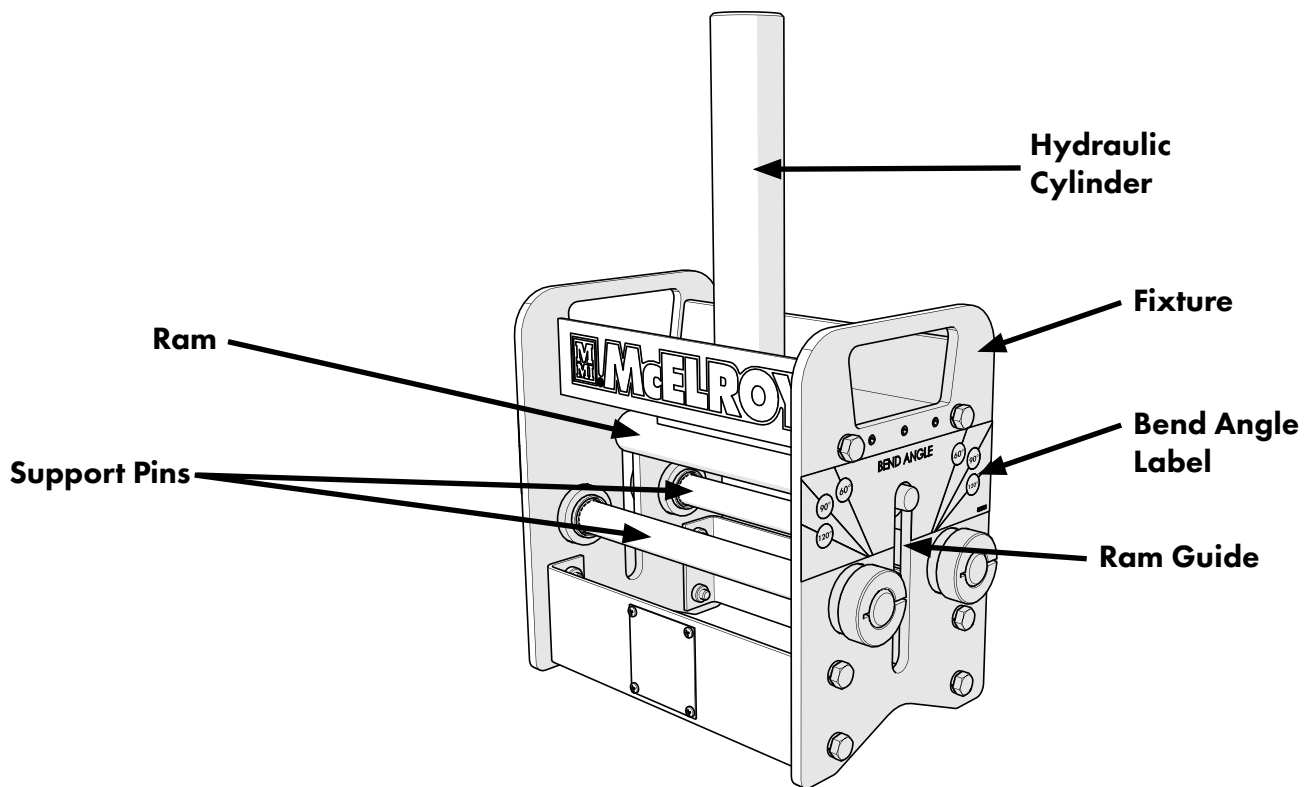

TX04362-02-10-15



Overview



Pump

The guided side bend tester has a manually operated hydraulic pump that is used to apply hydraulic fluid to the cylinder in order to move the ram. The pump has a pressure release valve on the right side of the pump.

The tester hydraulic pump has a gauge. The gauge is used for reference and is not considered part of the qualitative testing process.



PH04572-10-10-11

TX04363-11-1-11

Pressure Release Valve

The pressure release valve is used to unload pressure in the hydraulic pump. The valve turns clockwise to close and counter-clockwise to open.

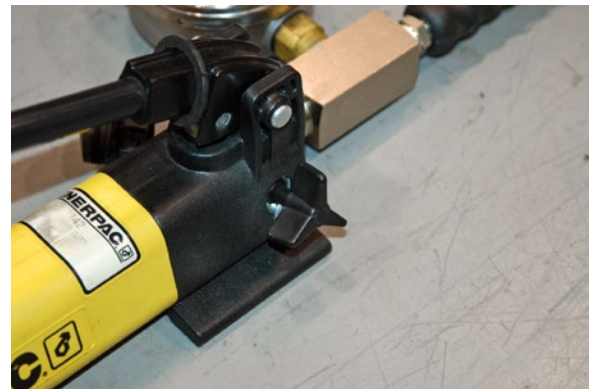

PH04570-10-10-11

TX04364-11-1-11

Coupon

The coupon is the result of making a cross section cut, sawing out a rough cut segment. The coupon is planed to a specified thickness with the fusion joint in the center.



PH04563-10-10-11

TX04365-11-1-11

Additional Tools

There are some tools that will be required (not included) to complete the preparation of the coupon for testing.

A drill may be used to produce starting points for saw cuts.

- Marking tool and straight edge to layout the rough cut segment.
- A reciprocating saw with a coarse woodcutting blade, chain saw, or band saw is used to cut a rough cut segment from the fusion joint.
- A small table planer is used to produce smooth and parallel surfaces to a specified thickness.
- Hand calipers to measure the thickness of the coupon.



PH04168-5-20-10



PH04169-5-20-10



PH04561-10-10-11

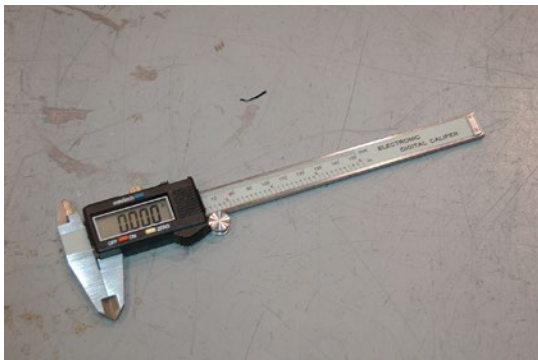

PH04573-10-10-11



Operation



Read before Operating

Before operating this machine, please read this manual thoroughly and keep a copy with the machine for future reference.



TX00838-1-5-96

PH01054-2-20-97

Cutting Rough Cut Segment

Allow the joint to cool before producing samples.

Mark out a 1 inch section of the pipe about 12 inches to 18 inches long with the fusion joint centered between the ends of the pipe. Testing specifications may require multiple coupons from the same fusion joint.

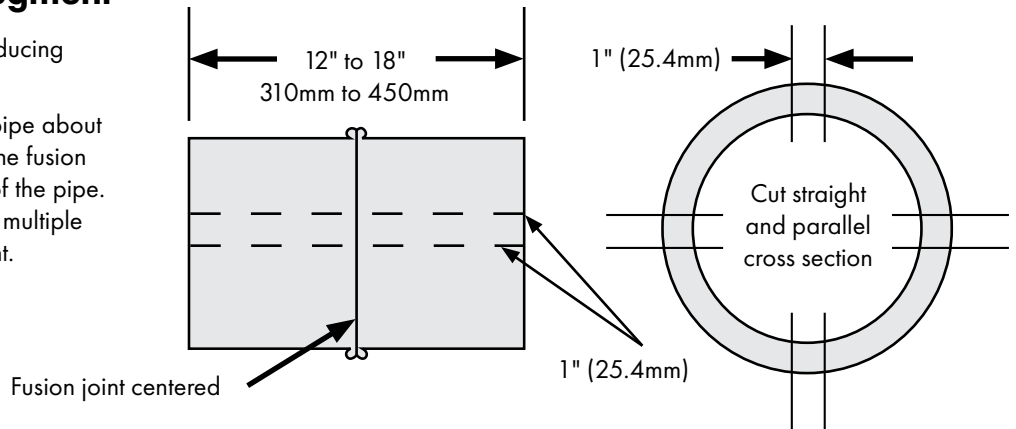

Cut the pipe on the designated markings using a reciprocating saw, chain saw, or band saw.

IMPORTANT: The use of a drill to make saw starting holes may be useful if sawing from a large section of pipe.

The result should be a rough cut segment that is roughly 1 inch thick and 12 to 18 inches wide.

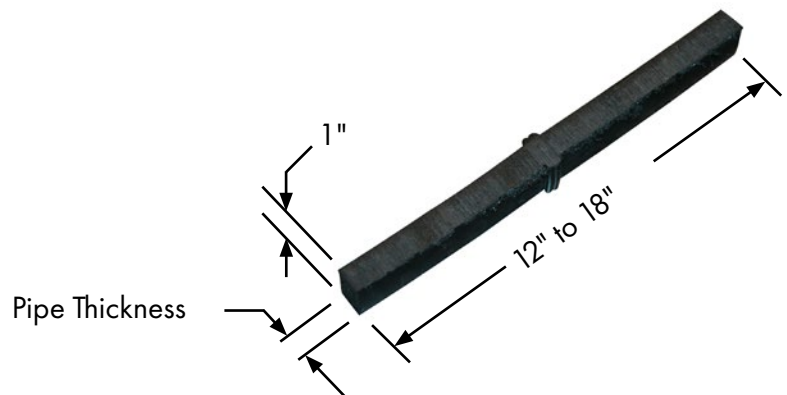

TX04367-11-1-11

PH04560-10-10-11

PH04559-10-10-11



Operation



Plane the Rough Cut Segment

Once cut out, inspect the rough cut segment.

Make sure there are no distinct ridges or parts of the pipe that will get snagged in the planer. The planer will make deep gouges into the coupon if such ridges exist.

CAUTION Ridges on the coupon could be caught in the planer forcing the coupon toward the user causing minor injury. Ensure the coupon has no ridges before planing.

Use the planer to create smooth and parallel surfaces of the specified thickness.

Begin slowly, using small increments of adjustment to the planer each time the coupon passes through the planer. Start the planer depth slightly larger than the maximum thickness of the coupon.

Insert the coupon into the planer.

Repeat inserting the coupon into the planer, making small adjustments to the depth each time it is inserted. Periodically flip the coupon to the opposite side to ensure that both sides achieve the same flatness.

The planer will pull the coupon through, there is no need to force the coupon.

Plane the coupon to the specified thickness within the tolerance of your bend test specifications. Tighter tolerances will improve the precision of your results. Measure at the bead.

The unit ships with a 1 inch diameter ram. Bend test specifications may require you to use a specific radius/thickness ratio*. The table below gives the coupon thickness based on the radius/thickness ratio with a 1 inch diameter ram. Coupon thickness should not exceed 0.5" (12.70mm). A 2 inch ram is available as an optional accessory.



PH04561-10-10-11



PH04562-10-10-11

1 inch Diameter Ram		
Desired radius/thickness ratio	Ram Diameter	Coupon Thickness
1	1" (25.4mm)	0.5" (12.70mm)
1.6	1" (25.4mm)	0.31" (7.87mm)
2	1" (25.4mm)	0.25" (6.35mm)
2.5	1" (25.4mm)	0.20" (5.08mm)

2 inch Diameter Ram (Optional)		
Desired radius/thickness ratio	Ram Diameter	Coupon Thickness
2	2" (50.8mm)	0.5" (12.70mm)
2.5	2" (50.8mm)	0.4" (10.16mm)

* Refer to ASTM F3183-16 for the recommended radius/thickness ratio.



Operation



Test the Coupon

Allow the coupon to come to temperature in a $73^{\circ}\text{F} \pm 5^{\circ}$ ($23^{\circ}\text{C} \pm 2.8^{\circ}$) environment.

IMPORTANT: In the field, a truck cab or temporary building can be used to bring the coupon to temperature.

Insert the coupon into the guided side bend tester, laying flat with the beaded section directly under the top bar, and on top of the side bars.

The alignment here is critical so as to test the right portion of the pipe. Misalignment can cause flawed results and errors in testing.

Turn the pressure release valve to close. Pump the hydraulic pump handle at a medium speed, keeping a constant pace.

Stop pumping the handle when the coupon has been bent up to the angle required by the test specifications. The bend angle label on either side of the tester will help determine if you reached the desired bend angle. The yellow label will indicate the exterior bend angle and the white label will indicate the interior bend angle. If there is no other guidance or specification we recommend a bend angle of 90° - 120° (yellow label) or 90° - 60° (white label).

NOTICE: Do not exceed specified bend angle. Excessive pressure will damage the tester and/or invalidate results.

Release pressure in the tester by opening the pressure release valve.

Remove the coupon from the tester.

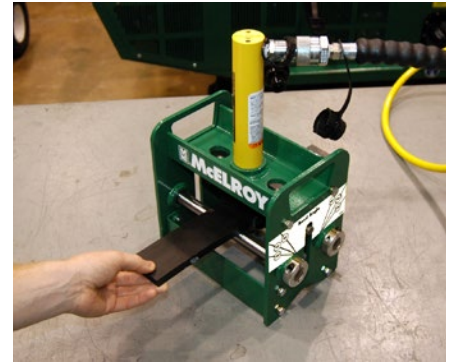

PH04664-04-04-14



PH04665-04-04-14



PH04666-04-04-14

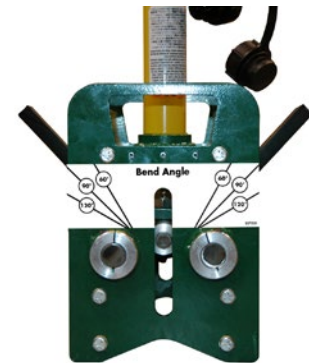

PH04667-04-04-14

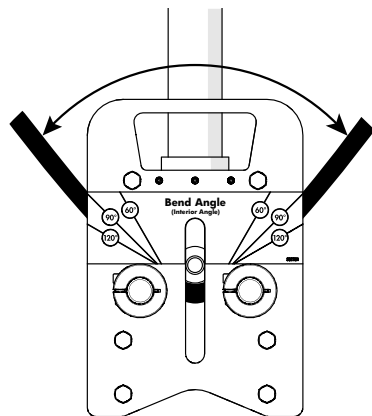

**90°
Interior Angle
(white label)**

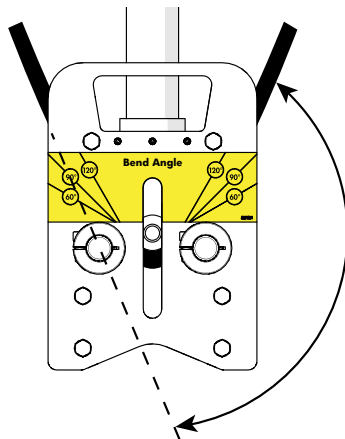

**120°
Bend Angle
(yellow label)**



PH04567-10-10-11

TX04369-02-10-15-

Interpretation of Results

Inspect Coupon/Interpret Result

- A)** The coupon breaks in the joint which is a failing result.
- B)** The coupon has tears in the joint which is a failing result.
- C)** The coupon stretches but does not break or crack in the fusion.

If the coupon does not pass, examine that you are doing everything properly and isolate the cause of the failing result.

Areas to Examine

• Testing Procedure

- Was coupon to specifications?
- Were there scratches?
- Was surface smooth?
- Were widths correct?
- Were the pipe and joint temperatures the same?
- Was test performed at too cool a temperature?

• Fusion Procedure

- Is the fusion procedure you are using a qualified procedure?
- Are you following the procedure properly?
- Use a DataLogger® with the fusion machine to verify the procedure is correct.
- Was the proper cooling time for the joint used?

• Adverse Conditions

- Was the fusion joint made in an extreme ambient temperature situation?
- Was the fusion joint made in inclement weather (rain/snow etc)?
- Was the fusion joint made during excessive wind?

• Joint Contamination

- Did the ends of the pipe have contamination before the fusion took place?

• Operator Qualification

- Is the operator qualified to perform the procedure and visually inspect the resultant fusion?

• Fusion Equipment

- Is the equipment in good repair?
- Is the equipment clean?
- Does the equipment perform to specifications?

• Handling

- Was the pipe with the fusion joint subjected to any rough handling?

• Material

- Is the material in accordance with specifications?



PH04607-11-7-11

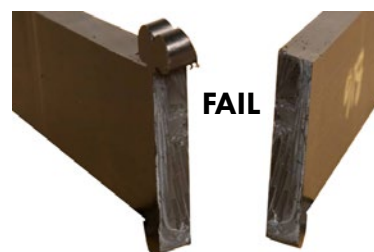

PH04606-11-7-11



PH04605-11-7-



PH04604-11-7-11



Maintenance



Preventative Maintenance

To insure optimum performance, the machine must be kept clean and well maintained.

With reasonable care, this machine will give years of service. Therefore, it is important that a regular schedule of preventive maintenance be kept.

Store machine inside, out of the weather, whenever possible.

TX00428-8-10-95

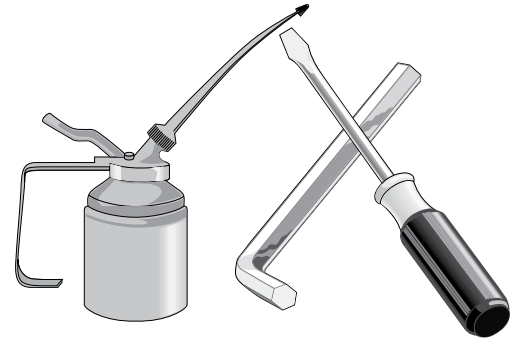

CD00142-11-2-94

Cleaning the Machine

Clean the machine with a soap and water wash as needed.

TX04082-5-25-10



CD00178-5-3-96

Check Hydraulic Fluid

The hydraulic fluid level should be checked periodically.

If the hydraulic oil is not full when the cylinder is retracted, oil must be added. Do not overfill.

If the pump and cylinders are empty, fill pump with oil and move the cylinder fully 3 times and check the fluid level and fill. Bleeding the hydraulic system is required when system has been empty. Refer to "Bleeding the Hydraulic System" section for instructions on bleeding the hydraulics.

Refer to the pump manufacturers recommendation for hydraulic fluid.

TX04371-11-7-11



PH04569-10-10-11



Bleeding the Hydraulic System

Pump the machine moving the cylinder down and releasing the pressure several times.

When bled, the machine should move immediately when pumped. Any pause may indicate that there is air still in hydraulic system. Repeat the pumping of the machine and then check the pump again.

If the cylinder moves immediately then there is no air left in the system.



PH04572-10-10-11

TX04372-11-7-11

Fasteners Must Be Tight

Check all nuts, bolts, and snap rings to make certain they are secure and in place.

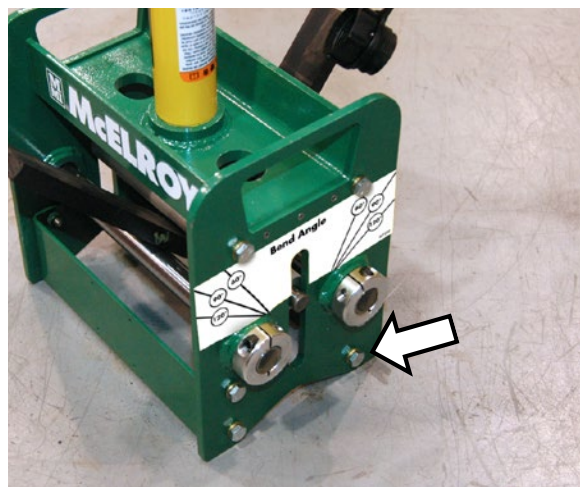

PH04666-3-9-12

TX00437-9-13-94



Maintenance Checklist



Guided Side Bend Tester Checklist

Item to Check	Satisfactory	Needs Repair	Repair Comments
UNIT			
Machine is clean			
Support pins rotate freely			
Machine is free of hydraulic leaks			
Hydraulic pump is filled to correct level			
All hardware is on the machine			
Hydraulic gauge shows pressure			
All nuts and bolts are tight			
Hydraulic pump handle is in place			
Ram moves smoothly through guides			

TX04373-11-7-11



Specifications



Guided Side Bend Tester

Specifications:

Designed to field test fusion joint coupons

- Qualitative testing of a joint in the field
- Can produce coupons from up to 7" thick pipe wall
- Hand pump system tests coupon

Pressure Rating:	200 psi (13.8 bar) - 1st Stage 10,000 psi (700 bar) - 2nd Stage
Max. Handle Effort	78 lbs. (35.4 Kg)
Stroke	5" (127mm)
Usable Oil Capacity	20 in ³ (328 cm ³)

Dimensions:

Width:	10.04" (255.0mm)
Length:	6.00" (152.4mm)
Height:	14.59" (370.6mm)

Weight: 31 lbs. (14.1 Kg) Guided Side Bend Tester

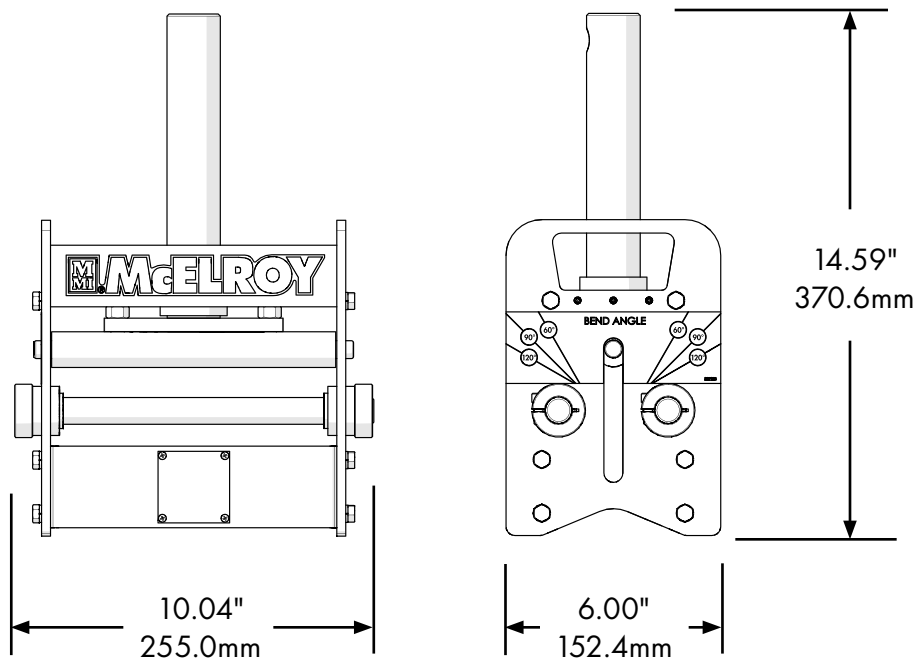

About this manual . . .

McElroy Manufacturing continually strives to give customers the best quality products available. This manual is printed with materials made for durable applications and harsh environments.

This manual is waterproof, tear resistant, grease resistant, abrasion resistant and the bonding quality of the printing ensures a readable, durable product.

The material does not contain any cellulose based materials and does not contribute to the harvesting of our forests, or ozone-depleting constituents. This manual can be safely disposed of in a landfill and will not leach into ground water.

TX001660-8-19-99



P.O. Box 580550 Tulsa, Oklahoma 74158-0550, USA

www.mcelroy.com