

## Overview

This kit converts a MegaMc® 824 and 1236 and TracStar® 630 and 900 carriage to work on the new TracStar Series 2 vehicle.

## Tools Required

- Assorted wrenches
- Flat-Tip screwdriver

## Kit Contains

### Parts List For Tracstar 900/MegaMc 1236 Carriage Hydraulic Conversion

<u>Part No.</u>	<u>Qty.</u>	<u>Description</u>
MFC00067	4	8FPT/12MSAE ADAPTER
MFC00221	4	10MSAE/8FPT ADAPTER
MFH00096	3	5/8FSAE QUICK DISCONNECT COUPLER
MFH00097	3	3/4FSAE QUICK DISCONNECT COUPLER
MFH00099	3	5/8FSAE QUICK DISCONNECT NIPPLE
MFH00100	4	3/4FSAE QUICK DISCONNECT NIPPLE
MFQ00056	1	8MSL/12MSAE ADAPTER
MFQ00088	2	8MSL/10MSAE ADAPTER
SLCYEYE056	2	HOSE ASSY OAL 56"
SLCYEYE058	1	HOSE ASSY OAL 58"

### Parts List For TracStar 630/MegaMc 824 Carriage Hydraulic Conversion

<u>Part No.</u>	<u>Qty.</u>	<u>Description</u>
MFC00067	4	8FPT/12MSAE ADAPTER
MFC00221	4	10MSAE/8FPT ADAPTER
MFH00096	3	5/8FSAE QUICK DISCONNECT COUPLER
MFH00097	3	3/4FSAE QUICK DISCONNECT COUPLER
MFH00099	3	5/8FSAE QUICK DISCONNECT NIPPLE
MFH00100	4	3/4FSAE QUICK DISCONNECT NIPPLE
MFQ00056	1	8MSL/12MSAE ADAPTER
MFQ00088	2	8MSL/10MSAE ADAPTER
SLCYEYE045	1	HOSE ASSY OAL 45"
SLCYEYE046	1	HOSE ASSY OAL 46"
SLCYEYE050	1	HOSE ASSY OAL 50"

### Parts List Electrical Conversion

<u>Part No.</u>	<u>Qty.</u>	<u>Description</u>
T9060501	1	240V HEATER POWER PIGTAIL CABLE ASSY
T9060502	1	HEATER RTD PIGTAIL CABLE ASSY
T9055401	1	CARRIAGE RTD CABLE
T9055501	1	HEATER POWER CABLE
T9033001	1	INDEXER HEATER CONNECTION BULKHEAD
MLK00114	1	1" STRAIN RELIEF CONNECTOR
MLM00368	1	4 X #10 RING TERMINAL
MAH00193	4	#10-24NCX1LG PHPMS
MBC00004	4	#10-24NC MACH SCR NYL LCK NUT
MAN00033	4	#4-40NCX1/2LG BHSCS SS
MQF00519	1	SIZE 18 X 4-40 NUT PLATE
3668001	1	36/T900 STOP-START SW BOX ASSY
MAB00033	2	5/16-18NCX1LG HHCS
MBA00006	2	5/16-18NC FNSH HEX NUT STL PL
MBE00006	2	5/16 REG SPLT LCK WSHR STL PL
T9051601	1	SWITCH BOX INTERCONNECT CABLE
MLN00112	20	11.5" X .19" CABLE TIE

Kit includes this instruction sheet

**Procedure: Electrical****Remove Old Cables:**

1. Loosen both strain relief connectors on the heater pivot arm junction box.
2. Remove lid from heater pivot arm junction box.
3. Loosen terminals and pull both cables out of pivot arm junction box.

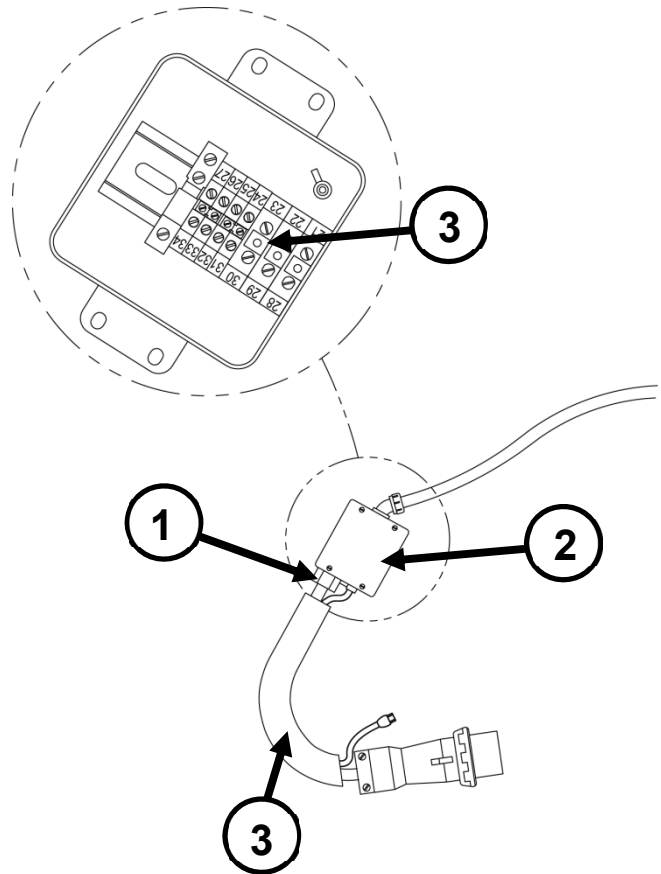
**Install New Cables:**

4. Replace 1" strain relief with MLK00114.

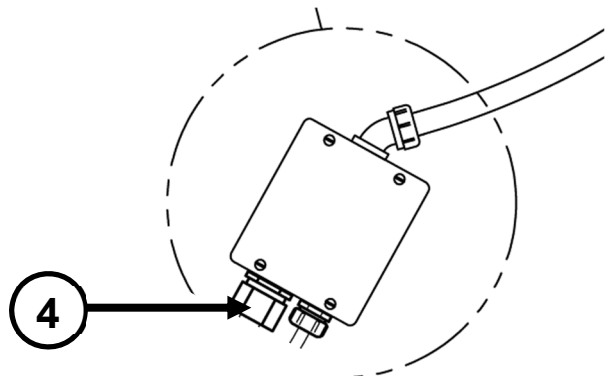

5. Run both pigtailed through existing cable sleeve.

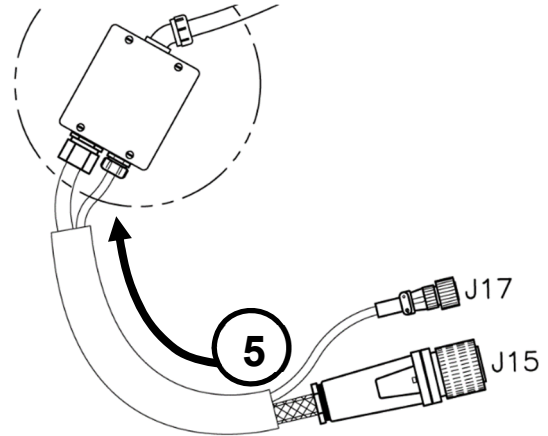

6. Insert power cable into large strain relief and connect BLACK, WHITE, and RED wires to terminals 21, 22, and 23.

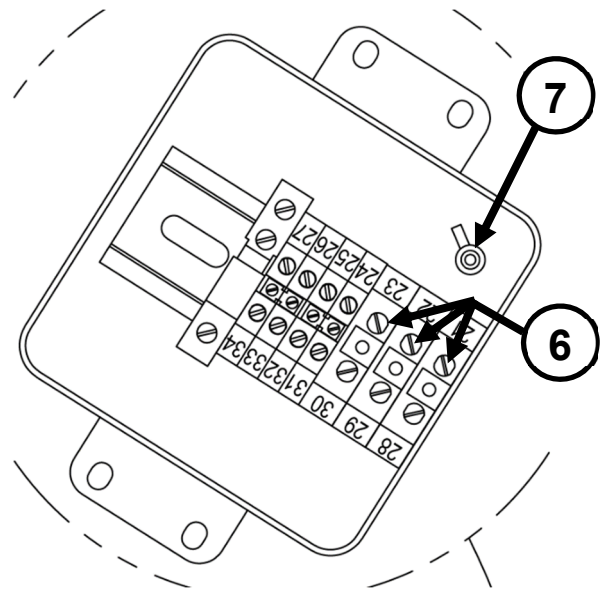

7. Crimp MLM00368 ring terminal to GREEN wire. Connect ring terminal to ground - inside box.

8. Tighten strain relief.

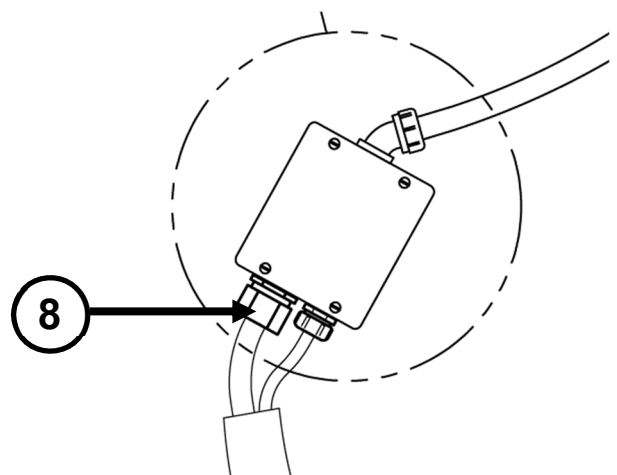

9. Insert T9060502 Heater RTD Pigtail Cable into 1/2" strain relief. 1

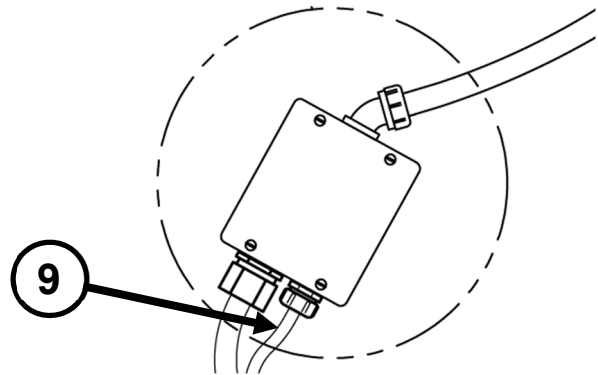

10. Connect  
GREEN wire to terminal 24  
YELLOW wire to terminal 25  
BROWN wire to terminal 26  
WHITE wire to terminal 27.

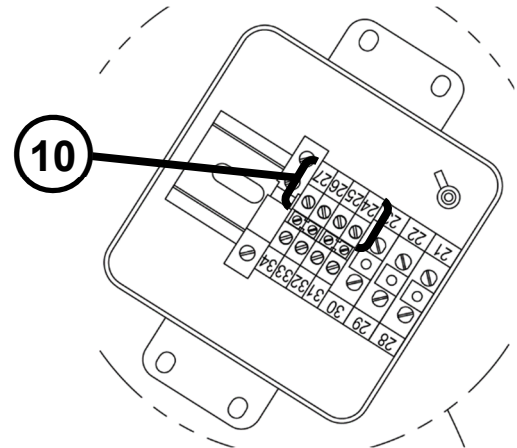

11. Tighten strain relief.

12. Re-install junction box lid.

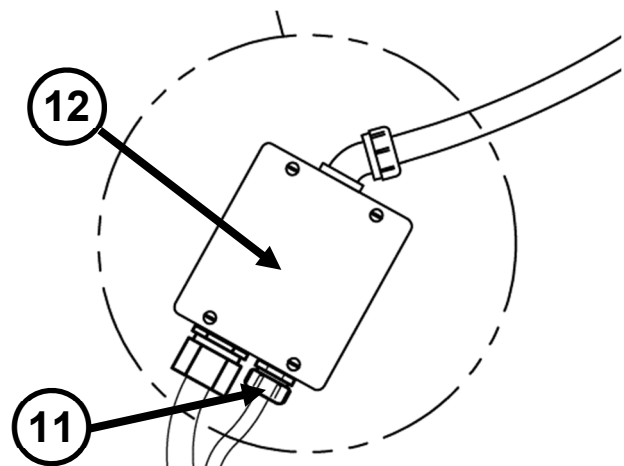

**Install Bracket:**

13. Remove receptacle box and heater power cable from indexer. Save the hardware from the receptacle box to install the new bracket.

Install the new receptacle bracket T9033001 using the hardware from the receptacle box.

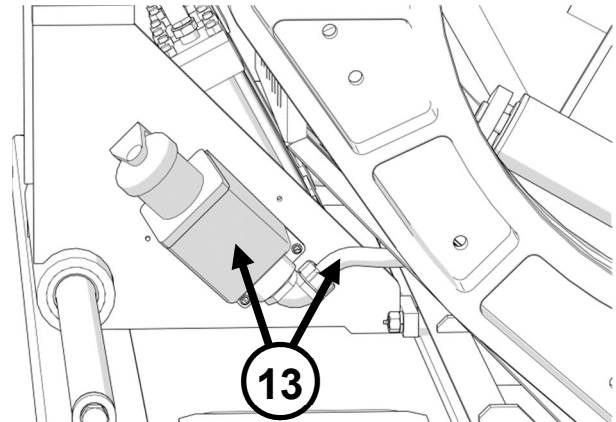

14. Mount T9055501 Heater Power Cable female connector in bracket with MAH00193 screws (4 ea.) and MBC00004 nuts (4 ea.).

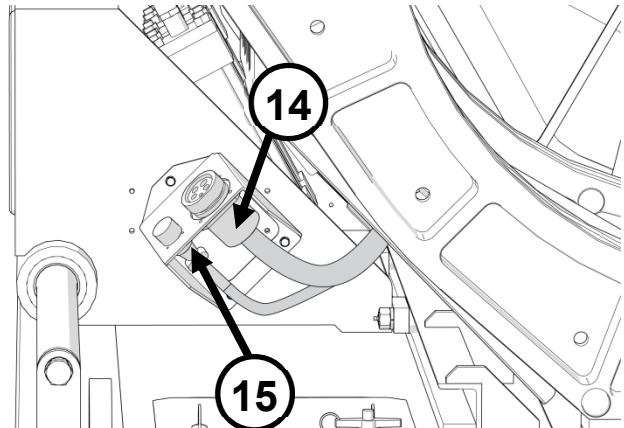

15. Install T9055401 Carriage RTD Cable in bracket with MAN00033 screws (4 ea.) and MQF00519 nut plate.

16. Route cables to the carriage bulkhead using cable ties MLN00112 to retain.

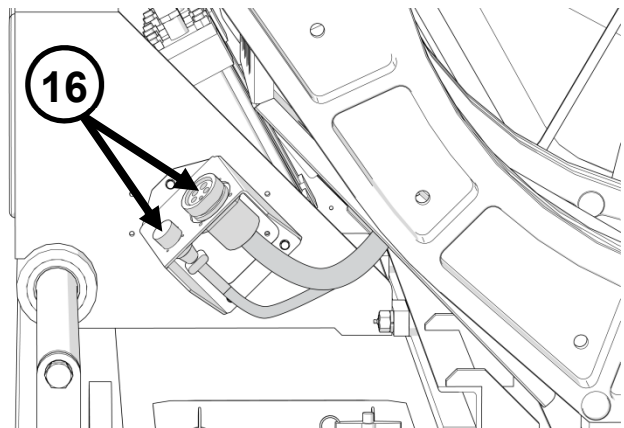

17. Plug heater cables into connectors at bracket.

### Install Start-Stop Box:

18. Locate the lifting eye bracket on the Inner Moveable Jaw.

On a TracStar® 900/MegaMc 1236, the Start-Stop Switch Box will mount on top of the horizontal section of the bracket.

On a TracStar® 630/MegaMc 824, the Start-Stop Switch Box will mount below the horizontal section of the bracket.

Carefully remove lid from Start-Stop Switch Box.

Align box mounting holes with two outer holes on horizontal section of bracket. Mount the Start-Stop Switch Box 3668001 with MAB00033 bolts (2 ea.), MBA00006 nuts (2 ea.), and MBE00006 washers (2 ea.). Install the lid to the Start-Stop Switch Box and orient the lid according to the machine installed on.

19. Route Start-Stop Switch Box cable to the outer moveable jaw. Secure to hydraulic hoses with cable ties.

**NOTE:** Route the cable behind the hoses and gauge to keep the area around valve shift levers clear.

20. Route cable alongside hydraulic hoses that run next to the outer moveable jaw.

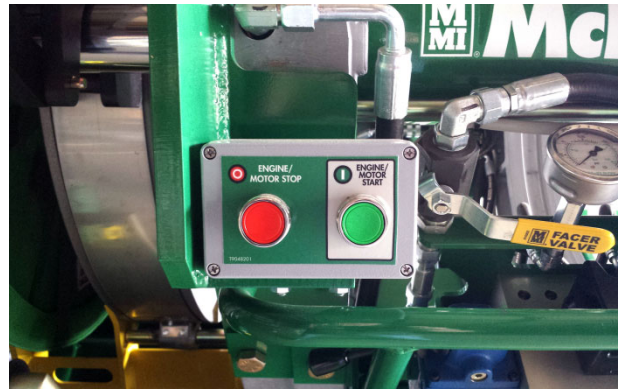

TracStar® 900/MegaMc 1236



TracStar® 630/MegaMc 824



21. Connect one end of T9051601 Switch Box Interconnect Cable to switch box cable.

22. Continue to route cable alongside hydraulic hoses. Follow path of hoses from indexer side of carriage to provide slack for carriage movement. Secure cable to hydraulic hoses.

Place connector on carriage deck next to the bulkhead. Secure cable to hydraulic hoses.

**NOTE:** There will be excess cable length on the TracStar 630/MegaMc 824. Bundle excess cable and secure with cable ties.

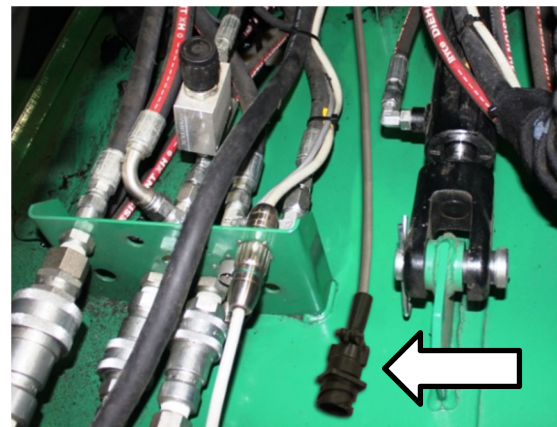
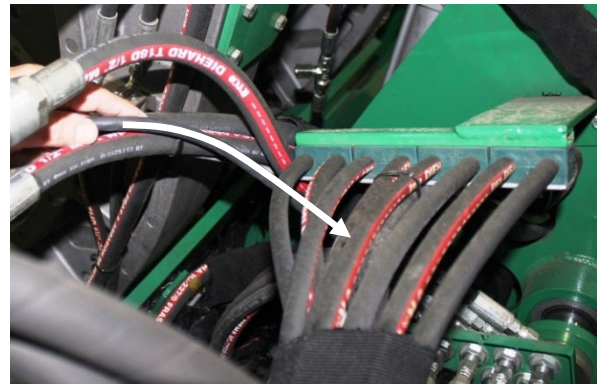

## Procedure: Hydraulic

### Replace Quick Disconnects (QD) At Four Jaw Carriage Terminal Plate (For TracStar 630 and 900/MegaMc 824 and 1236 Carriages)

23. Remove the carriage facer QD (larger of the two male QD's) and replace it with the new male MFH00100 QD.

**NOTE:** reuse the ½ female NPT X #12 male SAE adapter that is in the end of the old QD.

24. Remove the carriage female QD and replace it with the new MFC00221 adapter and new female MFH00096 QD.
25. Remove the carriage male QD (smallest of the two male QD's) and replace it with the new MFC00221 adapter and new male MFH00099 QD.

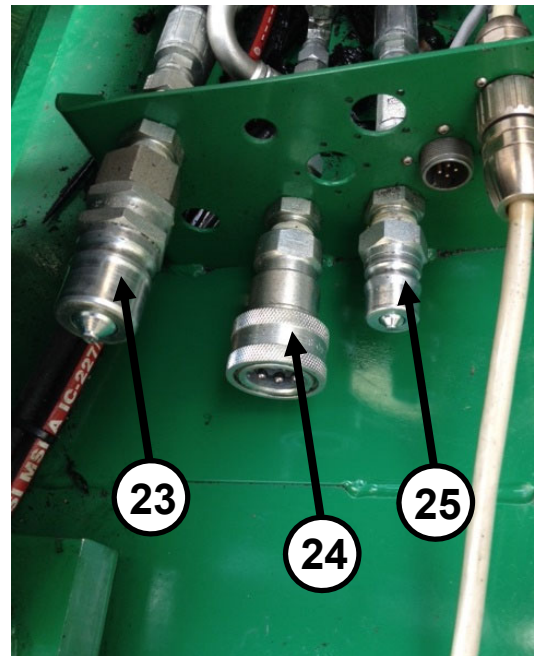

### Replace Quick Disconnects (QD) At Three Jaw Carriage Terminal Plate (For TracStar 630 and 900/MegaMc 824 and 1236 Carriages)

26. Remove the carriage facer QD (larger of the two male QD's) and replace it with the new male MFH00100 QD.

**NOTE:** reuse the ½ female NPT X #12 male SAE adapter that is in the end of the old QD.

27. Remove the carriage female QD and replace it with the new MFC00221 adapter and new female MFH00096 QD.
28. Remove the carriage male QD (smallest of the two male QD's) and replace it with the new MFC00221 adapter and new male MFH00099 QD.

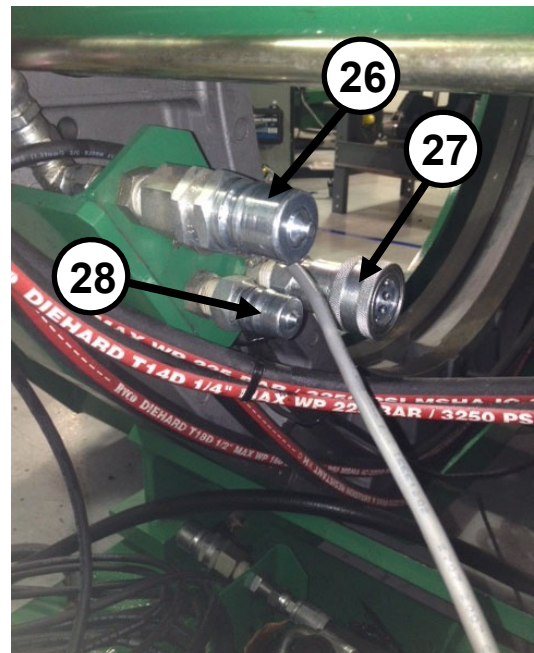

**Replace Quick Disconnects (QD) and Hoses Routed From the Four Jaw Terminal Plate to the Three Jaw Carriage Terminal Plate (For TracStar 900/MegaMc 1236 Carriages)**

29. Remove the carriage facer QD (larger of the two female QD's) and hose assembly. Replace them with the new female MFH00097 QD, new adapter MFQ00056 and the new SLCYEYE058 hose assembly.
30. Remove the carriage male QD and hose assembly. Replace them with the new male QD MFH00099, new adapter MFQ00088 and new hose assembly SLCYEYE056.
31. Remove the carriage female QD (smallest of the two female QD's) and hose assembly. Replace them with the new male QD MFH00096, new adapter MFQ00088 and new hose assembly SLCYEYE056.

**NOTE:** Reuse the protective hose sleeve when installing the new hoses.

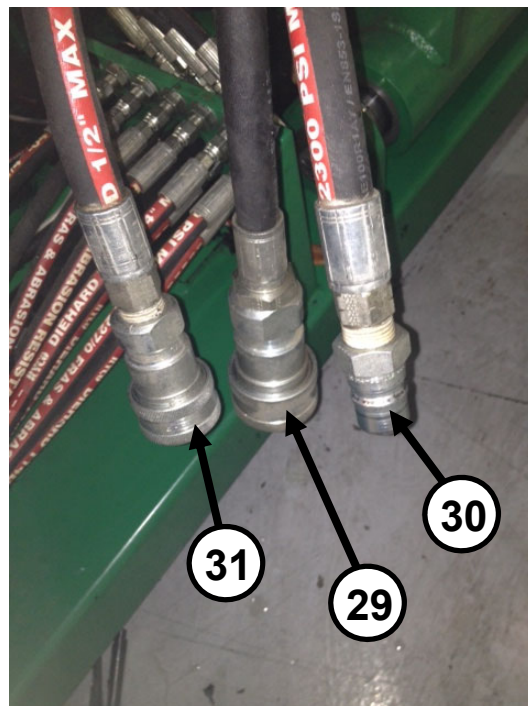
**Replace Quick Disconnects (QD) and Hoses Routed From the Four Jaw Terminal Plate to the Three Jaw Carriage Terminal Plate (For TracStar 630/MegaMc 824 Carriages)**

32. Remove the carriage facer QD (larger of the two female QD's) and hose assembly. Replace them with the new female MFH00097 QD, new adapter MFQ00056 and the new SLCYEYE050 hose assembly.
33. Remove the carriage male QD and hose assembly. Replace them with the new male QD MFH00099, new adapter MFQ00088 and new hose assembly SLCYEYE045.
34. Remove the carriage female QD (smallest of the two female QD's) and hose assembly. Replace them with the new male QD MFH00096, new adapter MFQ00088 and new hose assembly SLCYEYE046.

**NOTE:** Reuse the protective hose sleeve when installing the new hoses.

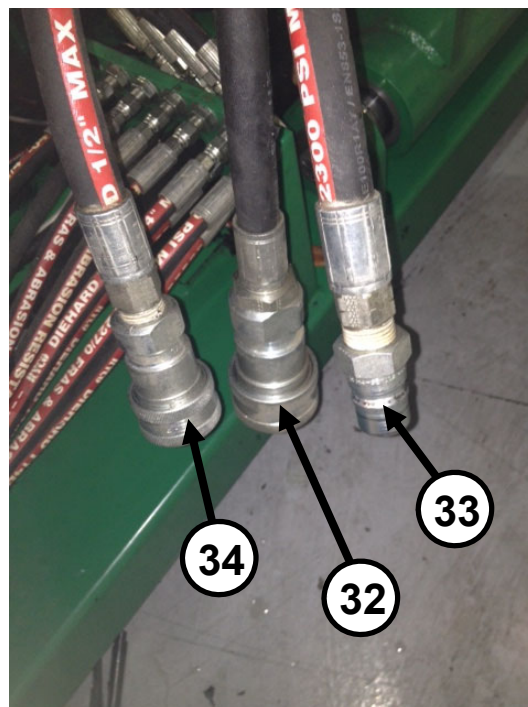

**Replace Quick Disconnects (QD) at the Facer Motor  
(For TracStar 900/MegaMc 1236 Carriages)**

35. Remove the female facer motor QD and replace it with MFC00067 adapter and new female MFH00097 QD.
36. Remove the male facer motor QD and replace it with MFC00067 adapter and new male MFH00100 QD.

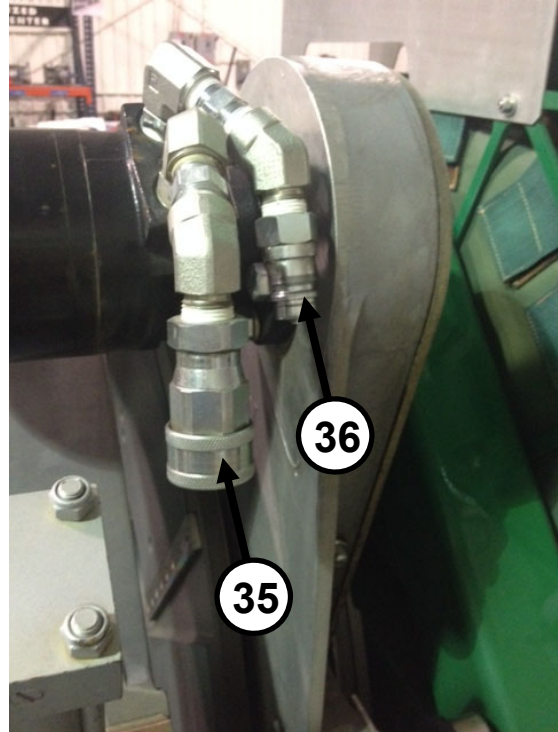
**Replace Quick Disconnects (QD) at the Facer Motor  
(For TracStar 630/MegaMc 824 Carriages)**

37. Remove the female facer motor QD and replace it with MFC00067 adapter and new female MFH00097 QD.
38. Remove the male facer motor QD and replace it with MFC00067 adapter and new male MFH00100 QD.

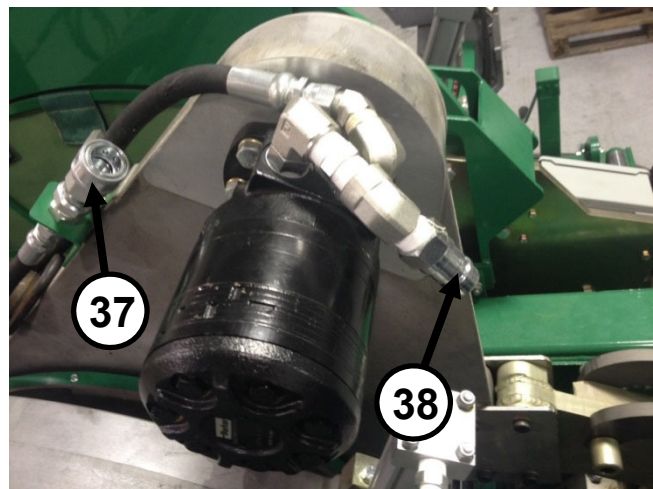

**Replace Quick Disconnects (QD) on the Facer Motor Hoses  
(For TracStar 630 and 900/MegaMc 824 and 1236 Carriages)**

39. Remove the male facer hose QD and replace it with MFC00067 adapter and new male MFH00100 QD.
40. Remove the female facer hose QD and replace it with MFC00067 adapter and new female MFH00097 QD.

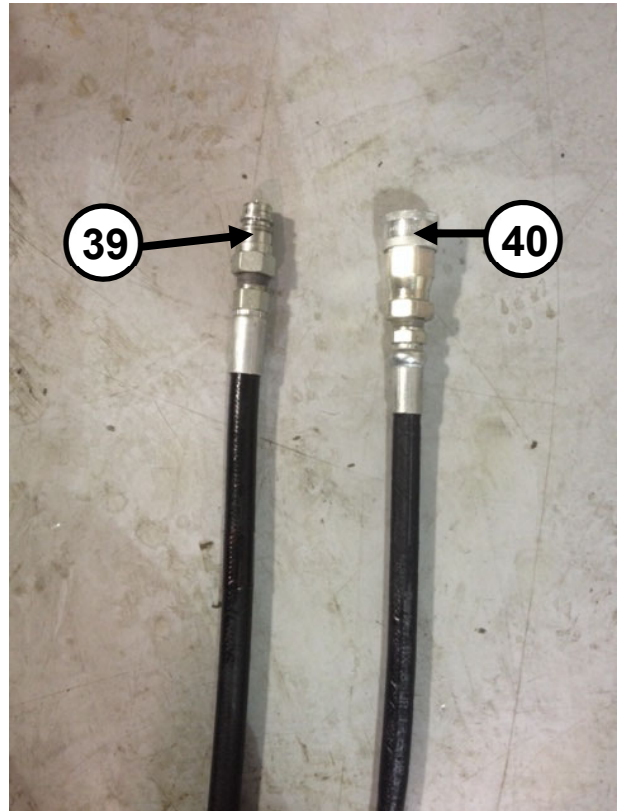

# INSTRUCTION SHEET REVISION HISTORY LISTING

**PART NO:** T242180101

**DESCRIPTION:** TracStar® 630/900 AND MegaMc® 824/1236 CARRIAGE TO SERIES 2 CONVERSION KIT

**ORIGINATOR:** BWJ      **CHECK:** SRB      **APPRV'D:** JBC      **RELEASED:** 11/3/16

<u>CHK/APR</u>	<u>REV</u>	<u>DATE</u>	<u>BY</u>	<u>DESCRIPTION OF REVISION</u>
BEA/BWJ	A	1/27/20	BEA	ADDED CARRIAGE RTD CABLE (T9055401) TO PARTS LIST.