



Machines Covered: MegaMc® 824, 1236, 1648, 2065 and 1600
TracStar® 630, 900 and 1200

California Proposition 65 Label Placement Instruction

The California Office of Environmental Health Hazard Assessment (OEHHA) amended regulations related to “clear and reasonable” Proposition 65 warnings (“Warning”) went into effect August 30, 2018. **For McElroy machines which are sold into and/or operated within California, the included label must be attached to the machine at the location specified below.**

The purpose of Proposition 65 is to ensure the public is informed about potential exposures to chemicals which the state of California has determined can cause cancer, birth defects, or other reproductive harm. The list now includes more than 900 chemicals. McElroy machines may contain trace amounts of listed compounds as a result of our manufacturing processes and materials.

Nothing has changed with McElroy’s products, and our machines are designed and manufactured to meet or exceed applicable product performance, safety, and health standards. The requirements for Prop 65 warnings have evolved, however, and these warnings are now required for California equipment. McElroy appreciates your assistance to ensure equipment operating in California is properly labeled. For more information about Proposition 65, go to www.P65warnings.ca.gov.

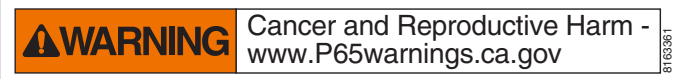

Part Number - 8163361

Label Instructions:

- 1) Clean the location for the label with a clean cloth and remove any debris from the area.
- 2) Remove the backing tape from the label.
- 3) Align the label as shown below and apply the label to the location.

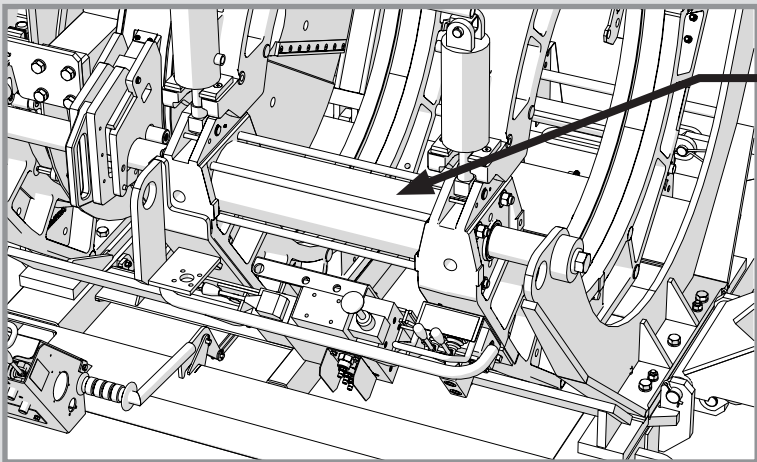

Operator Side Hydraulic Cylinder

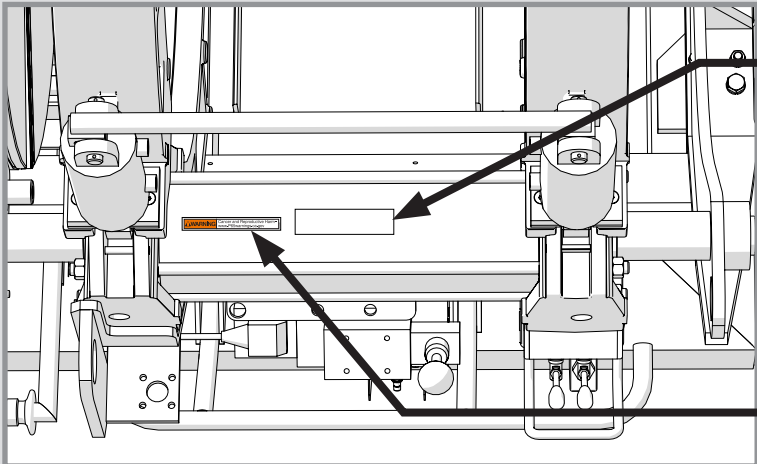

TEPA Label

Proposition 65 Warning Label

INSTRUCTION SHEET REVISION HISTORY LISTING

PART NO: 816336106

DESCRIPTION: CALIFORNIA PROPOSITION 65 LABEL PLACEMENT INSTRUCTION

MACHINES COVERED: MegaMc® 824, 1236, 1648, 2065 AND 1600

TracStar® 630, 900 AND 1200

ORIGINATOR: SRB CHECK: JBC APPRV'D: DDH RELEASED: 10/4/18

<u>CHK/APR</u>	<u>REV</u>	<u>DATE</u>	<u>BY</u>	<u>DESCRIPTION OF REVISION</u>
----------------	------------	-------------	-----------	--------------------------------